



ISSN NO. 2320-5407

Journal homepage:<http://www.journalijar.com>
Journal DOI:[10.21474/IJAR01](https://doi.org/10.21474/IJAR01)

INTERNATIONAL JOURNAL
OF ADVANCED RESEARCH

RESEARCH ARTICLE

Applications of cascaded H-bridges with storage systems integrated into the grid.

S.Pawan Kumar.

Department of Electrical and Electronics Engineering, Jeppiaar Institute of Technology, Chennai, India.

Manuscript Info

Manuscript History:

Received: 22 April 2016
 Final Accepted: 17 May 2016
 Published Online: June 2016

Key words:

DcSupply, Optocoupler,
 PIC microcontroller, Driver circuit,
 H-Bridge, MOSFET.

*Corresponding Author

S.Pawan Kumar.

Abstract

This paper emphasis the best efforts and technique in reduction of harmonic content of the sinusoidal waveform in ac voltage. This is done by increasing the number of steps. In general, number of bridges are determined by the formula $2N+1=Levels$, where N is the number of bridges, which leads to 10 bridges. But this project makes use of 4 H-Bridges. This is achieved by making use of asymmetrical multilevel inverter of different voltage source. Also the use of PWM is eliminated, which further reduces the harmonic content in the waveform.

Copy Right, IJAR, 2016., All rights reserved.

Introduction:-

In recent years, with the increase in load demand, increases the power production. So the government has been running many projects depending on renewable energy resources like water, wind, geothermal, tide and solar[1][2]. Among the renewable resources mentioned above, solar is found cheaper and affordable. Countries like India, Bangladesh, which lies along the equator, the availability of solar energy is plenty. But the energy obtained from this resource is being stored in a DC battery. But in many countries, which depend on AC voltage, there is a need to change this DC voltage to AC voltage. This is done with a help of inverter. Basically, Inverter makes use of many semiconductor switches like IGBT, MOSFET [3]. Selections on semiconductor switches are based on current and voltage rating. During the conversion of DC to AC voltage, the output AC voltage is not a pure sinusoidal waveform. There exist some harmonics and waveform distortion.

For the use of domestic purpose, these dc voltages are converted to ac using an inverter. But harmonics and waveform distortion arises in the output. Because of the harmonics the efficiency and life time of machine deteriorates constantly. Sometimes it may leads to damage of machine. So these harmonic contents need to be suppressed to the minimum level. This paper "Applications of cascaded H-bridges with storage systems integrated into the grid" deals with the reduction of these harmonic content.

Material and Methods:-

Power Supply & Optocoupler:-

DC batteries of voltage level 3V, 6V, 9V and 12V [4] are being used. This system is considered as asymmetrical multilevel inverters because of the use of different DC supply. 4n35 Optocoupler is being used for the purpose of isolation of two circuits magnetically. Optocoupler 4n35 is basically a 6 pin IC. It consists of an emitter diode and a phototransistor. The main purpose of optocoupler is to prevent one circuit whenever the fault occurs in another circuit.

PIC Microcontroller:-

PIC 16F877 (Peripheral Interface Controller) microcontroller has an operating frequency of 20 MHz which requires a 5V DC supply. The PIC microcontroller makes use of small number of fixed length instruction with most instruction being single cycle execution of four clock cycle. It has a main feature of power saving sleep mode.

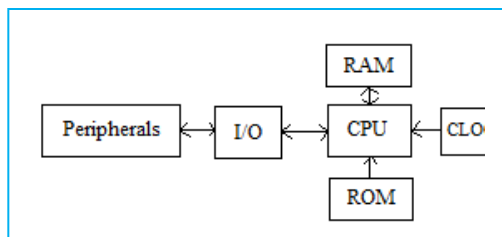

Fig.1. Block diagram of PIC microcontroller

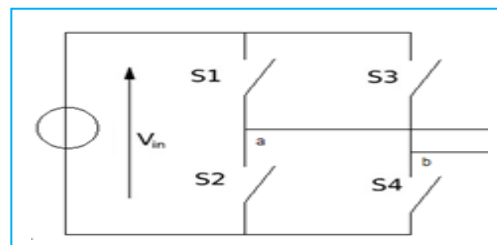

Fig .2 Basic Representation of H Bridge

H-Bridge:-

H-bridge consists of 4 power devices. Here we make use of MOSFET as the power devices as the current rating is less than 1 Amp. It should be made sure that no two switches of same branch should conduct at the same time. The switching state will be like S1 ON,S2 OFF and S3 OFF,S4 ON and vice versa. In 21 level symmetrical multilevel inverters [5], the number of H-bridges are determined by the formula $2n+1= \text{Level}$ where n determines the number of levels. This leads to make use of 10 H-bridges but our project makes use of 4 H-bridges to attain the same level through asymmetrical multilevel inverter.

Working of the system:-

The twenty one level asymmetrical multilevel inverter makes use of four different DC supplies of voltage rating 3V, 6V, 9V and 12V. Each DC supply is given as input for four H-bridges. The current for triggering the gate of MOSFET in H-bridge is fed through an optocoupler. The PIC microcontroller requires 5V DC supply. Thus the 230V supply is stepped down to 110V through a step down transformer,

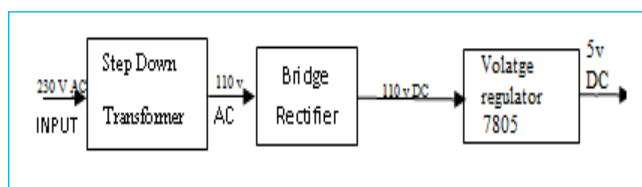

Fig.3 Power supply circuit for Optocoupler

and then converted into 110V DC voltage with the help of rectifiers. Now this 110V DC voltage is converted to 12V with the help of voltage regulator IC 7812. This is further reduced to 5V with the help of IC 7805.

The 5V supply is given as input for optocoupler. This 5V supply is connected to collector of phototransistor and gate of MOSFET. The working of the optocoupler is being controlled by PIC microcontroller. Two ports (PORT B and PORT D) together consist of 16 pins which are connected to 16 optocoupler. Turning ON and turning OFF of optocoupler is controlled by PIC microcontroller with proper delay in the program. Whenever the optocoupler is turned ON, the emitter diode emits light. As a result of which the current is fed through the base of the phototransistor. This results in the flow of current from collector to emitter which prevents the flow of current to gate of the MOSFET. Thus the MOSFET is in OFF state. When the optocoupler is turned OFF, the emitter diode does not glow and the flow of current from collector to emitter is prevented. This leads to the flow of current from supply to gate of the MOSFET. Thus the MOSFET is turned ON. As the MOSFETs are turned ON, the corresponding H-bridges work. This leads to the production of multiple steps that are required to attain 21 levels. Unlike symmetrical multilevel inverters, the H-bridges do not conduct for a very long period.

Advantages

1. As we use asymmetrical multilevel inverter, different combinations of voltage sources can be used.
2. Thus the number of semiconductor switches, space and cost are getting reduced which provides with high quality output.
3. The use of filter is eliminated as the harmonic contents are getting reduced by the steps.
4. When the asymmetry input voltage is properly design, it can minimize the redundant output level.
5. They can generate voltages with extremely low distortion and lower dv/dt .

Applications

1. Home Applications and Low power DC motor
2. In hill stations for glowing of lamps and tube light without any distortion.

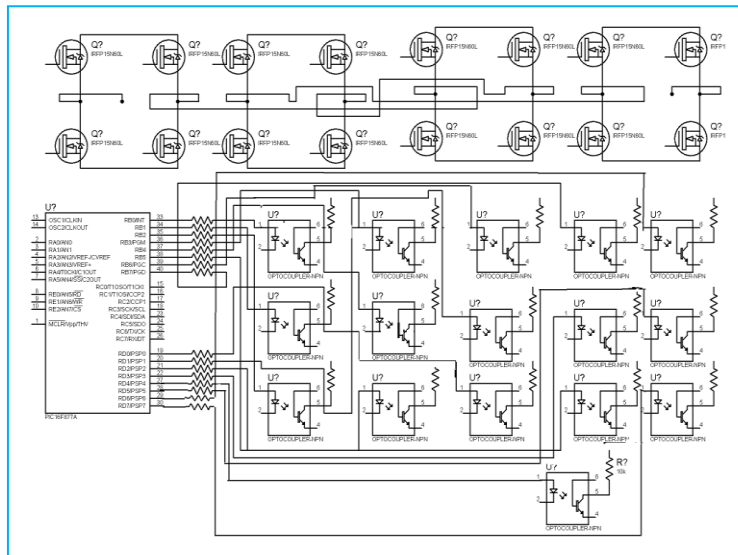

Fig.4 Hardware diagram

Step1	3volt,6volt,9volt,12volt
Step2	6volt,9volt,12volt
Step3	3volt,9volt,12volt
Step4	9volt,12volt
Step5	6volt,12volt
Step6	3volt,12volt
Step7	12volt
Step8	9volt
Step9	6volt
Step10	3volt
Step11	0volt
Step12	-3 volt
Step13	-6volt
Step14	-9volt
Step15	-12volt
Step16	-(3volt,12volt)
Step17	-(6volt,12volt)
Step18	-(9volt,12volt)
Step19	-(3volt,9volt,12volt)
Step20	-(6volt,9volt,12volt)
Step21	-(3volt,6volt,9volt,12volt)

Table.1 Formation of Twenty One Levels

Result and Discussion:-

Simulation and output waveform

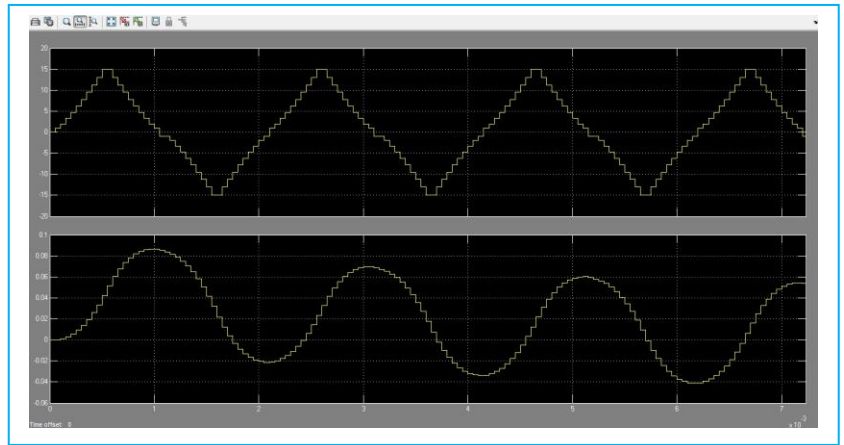
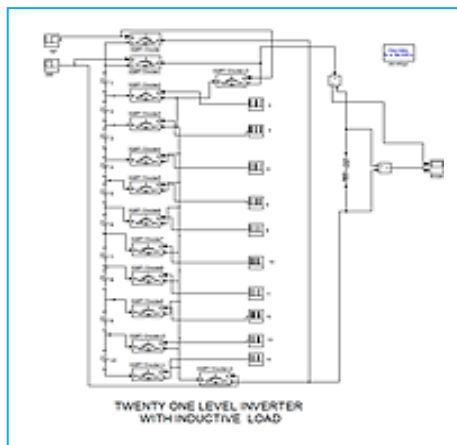

Fig.5. Simulation Diagram Fig.6. Output waveform

The 21 steps in the voltage waveform has been shown above. The simulation of a 21 level H-Bridge cascaded grid tied inverter was done using MATLAB and SIMULINK. This simulation makes use of IGBT instead of MOSFET and uses DC supply as an input source. The load connected is RL load. The output voltage obtained is 60V (peak to peak) which has been verified through simulation. The current obtained is found to be around 0.08 Amp. The output waveform is shown above.

Conclusion:-

This project has achieved twenty one level with use of less number of semi conductor switches, and reduced harmonic contents. It also helps in reducing the overall cost and thus providing the better quality AC output. This asymmetrical multilevel inverter has been found to have less THD in compare to that of symmetrical multilevel inverter.

References

1. J. M. Carrasco, L. G. Franquelo, J. T. Bialasiewicz, E. Galvan, R. C. P. Guisado, Ma. A. M. Prats, J. I. Leon, N. Moreno-Alfonso, "Power-Electronic Systems for the Grid Integration of Renewable Energy Sources: A Survey," *IEEE Transactions on Industrial Electronics*, vol. 53, no. 4, pp. 1002-1016, June 2006.
2. J. Morrison, "Global Demand Projections for Renewable Energy Resources," *IEEE Canada Electrical Power Conference*, 25-26 Oct. 2007, pp 537-542.
3. J. Rodriguez, S. Bernet, Bin Wu, J. O. Pontt, S. Kouro, "Multilevel Voltage-Source-Converter Topologies for Industrial Medium-Voltage Drives," *IEEE Transactions on Industrial Electronics*, vol. 54, no. 6, pp. 2930-2945, Dec. 2007.
4. S. A. Khajehoddin, A. Bakhshai, P. Jain, "The Application of the Cascaded Multilevel Converters in Grid Connected Photovoltaic Systems," *IEEE Canada Electrical Power Conference*, 25-26 Oct. 2007, pp. 296-301.
5. J. S. Lai, F. Z. Peng, "Multilevel Converters - A New Breed of Power Converters," *IEEE Transactions on Industry Applications*, vol. 32, no. 3, May/Jun. 1996, pp. 509-517.
6. K. N. V. Prasad ; Dept. of Electr. & Electron. Eng., MIC Coll. of Technol., "Comparison of different topologies of cascaded H-Bridge multilevel inverter" Computer Communication and Informatics (ICCCI), 2013 International Conference
7. NasrudinAbd. Rahim ; UM Power Energy Dedicated Advanced Center (UMPEDAC) "Transistor-Clamped H-Bridge Based Cascaded Multilevel Inverter With New Method of Capacitor Voltage Balancing" IEEE Transactions on Industrial Electronics (Volume:60 , Issue: 8)