



Journal Homepage: - www.journalijar.com

INTERNATIONAL JOURNAL OF ADVANCED RESEARCH (IJAR)

Article DOI: 10.21474/IJAR01/12972

DOI URL: <http://dx.doi.org/10.21474/IJAR01/12972>



RESEARCH ARTICLE

DESIGN OF AN AUTOMATED BOTTLE PACKAGING SYSTEM

Abhinav Baroorkar, Pavan Dolas, Adarsh Nagorao Dhule and Adwait Kulkarni

Mechanical Engineering Department, Sinhgad College of Engineering Pune, India.

Manuscript Info

Manuscript History

Received: 30 March 2021

Final Accepted: 30 April 2021

Published: May 2021

Key words:-

Automation, Industry 4.0, Mechatronics

Abstract

Industry 4.0 is changing the efficiency and output of current industries significantly. It is finding its way in every small application one can think of. Though in some small-scale industries in the developing countries are unable to afford such machines. Taking this into consideration this paper proposes a system to automate the process of packaging bottles by using different sensors and actuators, which will be affordable to the small industries. Automating this final stage in the production of different bottles, will not only increase the efficiency of the industry but also save a lot of money in the long run.

Copy Right, IJAR, 2021,. All rights reserved.

Introduction:-

Nowadays, automation in the manufacturing industries has become a global trend. The production lines in industries have become fully automatic and don't require an operator. Automation is certainly a necessity today, as manufacturers face razor-thin profit margins. Companies must automate every process in order to meet the customer's demand and deliver the product as fast as possible and at a fair price. Automation increases the manufacturing production, its flexibility, the variety of products and even reduces the cost of a product. In small industries bottle packing operation is done manually. The manual packing process has many shortcomings like, it requires a lot of time to pack the bottles. Especially in many small industries these problems reduce production rate, so to eliminate this problem this paper proposes an autonomous bottle packing system. This system is primarily targeted for small industries. With this system, the process will be automated and will be more efficient and the process of repacking can reduce the labour requirements and operation time. One more advantage of this system is that it makes the entire process contactless.

Packaging is the science, art and technology of enclosing or protecting products for distribution, storage, sale, and use. Packaging also refers to the process of designing, evaluating, and producing packages. Packaging can be described as a coordinated system of preparing goods for transport, warehousing, logistics, sales, and end use. Packaging contains, protects, preserves, transports, informs, and sells. In many countries it is fully integrated into government, business, institutions, industries, and personal use which results in higher profits. For instance, plastic packaging is available in industries, which works on the principle of vacuum extraction process.

Description Of The Industrial Process:

Currently, in the bottle manufacturing industries the production of the bottles is a fully automated process. But after a bottle is manufactured the packaging is done manually, which requires a lot of workers. Hence to increase speed, reduce costs and increase the overall efficiency of the process, we felt the need to develop this system and make this process completely self-sufficient. The automatic weighing and packaging machines provide a wide array of

Corresponding Author:- Abhinav Baroorkar

Address:- Mechanical Engineering Department, Sinhgad College of Engineering Pune, India.

applications for different industries. The greatest asset of a packaging and weighing the machines that are manufactured today are advanced and they provide effective coordination with other processes of the production lines in the best possible manner. It is important for the industries to abide by the standards set by the government, and also increase the quality and the production rate. Bottle packaging machines can be used for packing water bottles, pharmacy bottles, and many more consumer goods which are sold in a bottle. It can wrap a product with the weight of boxes ranging from 10 grams to 10 of kilograms. It pushes the product in a box and then seals the product centrally. It is based on the draw bar mechanism or belt drawdown mechanism. The entire packaging process is done with the help of electro pneumatics and motors. The control for the hardware is to be processed by a programmable logic controller via the computer. The whole system executes the following processes:

1. Regulate the bottles coming on the conveyor belt
2. Locating the position of the bottle using various sensors
3. Pushing the bottle in the packaging box
4. Sealing the box

Related Work:

Boca M.L., Kovac, P. Savković. B have studied that industry automation is the global trend in manufacturing. Packaging process is one of the most used in industry; more and more companies are switching to automation. This study report is about design and fabrication of an automated packaging machine system. The process of bottling and packaging of bottles is only partial part of the automation process. Previously used models for monitoring the process of bottling and packaging are used for study. Simulation of this model is done for improvisation of packaging process. This study report is about design and fabrication of an automated packaging machine system. From this data the author has optimized the process by setting specific time in the process. Hence it is concluded that the simulated model can be used for practical use. [1]

Prajakta Hambir et.al has studied the need of automation in packing industries. They have designed the entire weighing and packing process with help of electro pneumatics and motors. And divide the process as automation uses the microcontroller-filling of material into the bag- packaging- sealing and execute it with help of programmable logical control. They have designed a hopper for material filling and used a stepper motor for uniform and stable speed and it provides them constant torque. A load cell used in design is a sensor that converts a load or force or weight acting on it into an electronic signal. [2]

Bipin Mashilkar, Praseed Kumar focus on automating the process of filling bottles in this invention. Currently in some small-scale industries the work is done manually which leads to loss of time as well as the commodity. The authors have developed a micro-controller-based system for automating this process. The system they propose has a conveyor system and automatic filling station. The proximity sensor detects the position of bottles and the feedback is given to a microcontroller (Arduino) which triggers the actuators and valves. The system they propose is an open loop feedback system and the valve remains open based on time and volume calculations which are done manually. The bottles are placed in holders on a chain driven conveyor system. [3]

Sina Safinia et.al dealt with the recycling of plastic bottle waste and reusing it for concrete blocks in construction of buildings, walls, etc. They studied compressive strength by experimenting with concrete blocks under loads. They also studied the concrete blocks with voids and coarse mixture. Research led to the conclusion that the concrete blocks with plastic waste showed 57% increase in compressive strength than omani concrete blocks. This study also gave a method to recycle the plastic bottle waste. [4]

Design:

After bottles are manufactured, they are sent for packaging on a conveyor belt. When the bottles reach the end of the conveyor belt, the bottles roll down an inclined surface and a Geneva wheel mechanism regulates the bottles coming onto the conveyor belt. The fixture placed next to the wheel obstructs the bottle and a proximity sensor mounted next to it, detects the bottle. This sensor then sends a signal to a microcontroller which in turn actuates the pneumatic piston and the bottle is pushed into a box. These boxes are placed in the slots made for them on the conveyor belt. Moreover, there is flap closing assembly placed along the conveyor belt which will pack the box thoroughly. The dimensions of the entire system can be easily altered as per the requirements and this system can be easily modified according to the requirements.

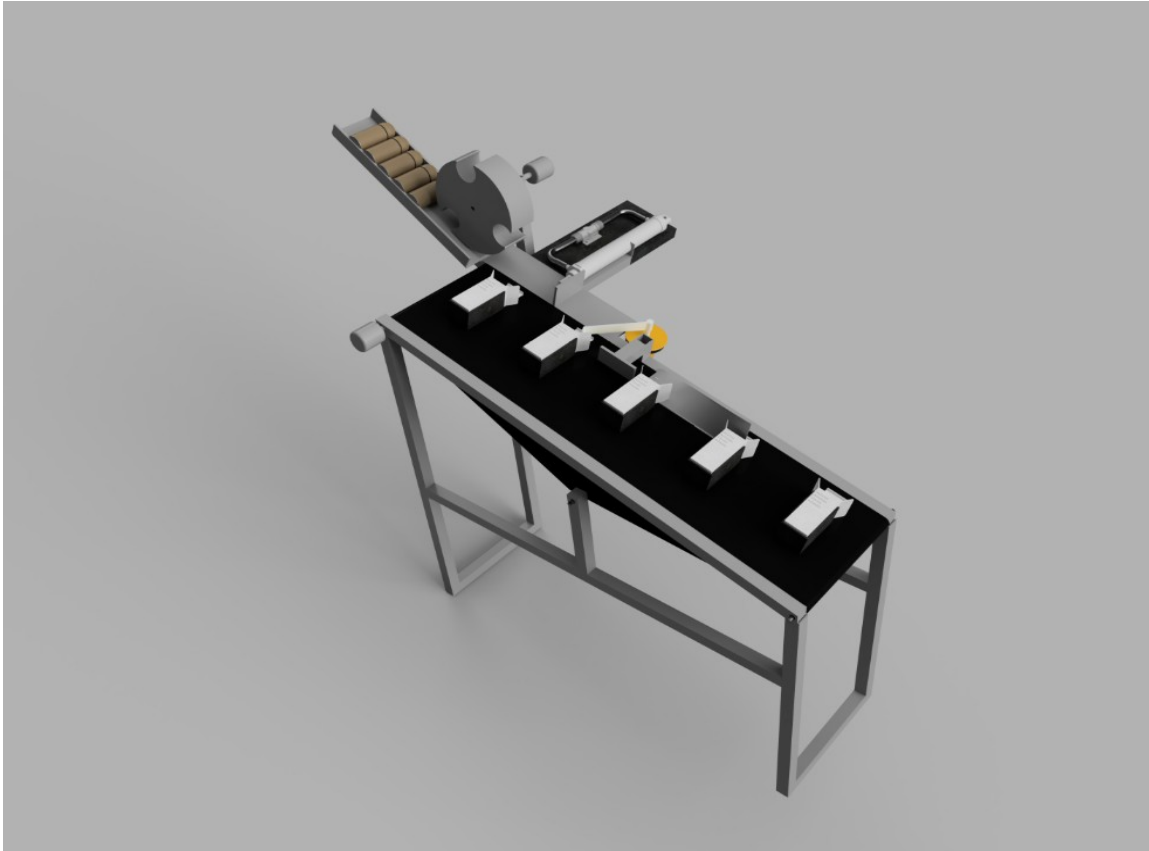

Figure 1:- Proposed System.

Frame and conveyor belt

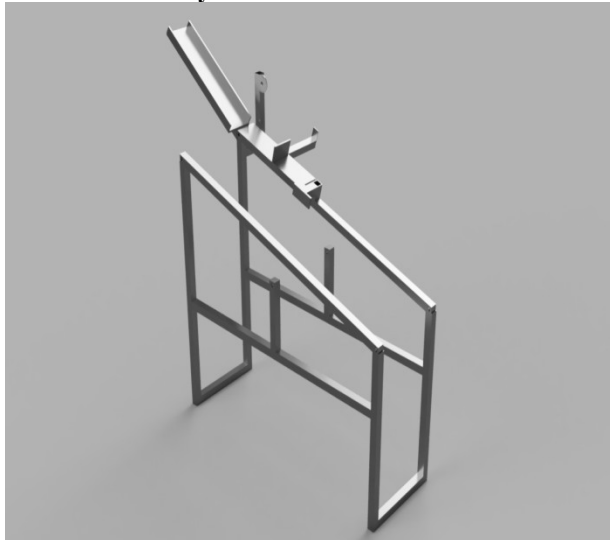

Figure 2:- Frame.

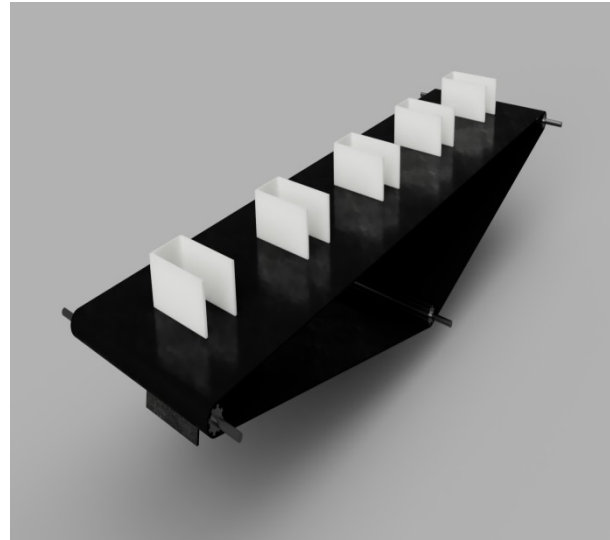

Figure 3:- Conveyor belt with slots.

Figure 2 shows the frame on which all the components can be mounted on. The dimensions and material of this frame can be selected according to the need of the user. Figure 3 shows the conveyor belt which will be driven by a motor. Slots can be mounted on the belt which may be used to hold the boxes for the bottles. The motors can be controlled using a microcontroller. For maintain the tension of the conveyor belt a tensioner should be placed in the slot made on the frame.

Geneva Wheel

Figure 4 shows a Geneva wheel, the main purpose of this wheel is to regulate the bottles coming onto the conveyor belt. As the wheel has to rotate a fixed angle after every bottle has been pushed into the box, the wheel should be rotated using a servo motor or a stepper motor.

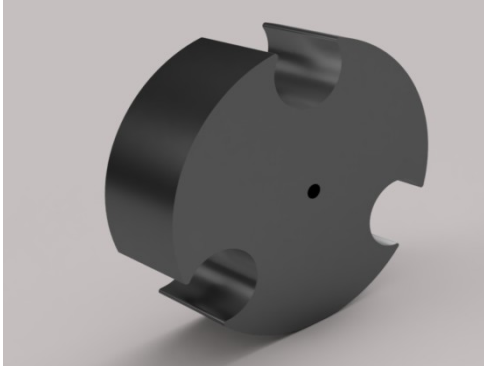

Figure 4:- Geneva Wheel.

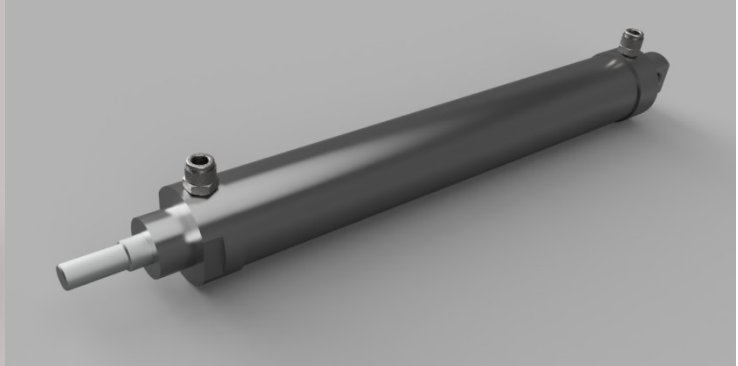

Figure 5:- Pneumatic Piston.

Pneumatic Piston

Figure 5 shows a pneumatic piston. A pneumatic piston is a mechanical actuator which uses pressurized fluid in order to create a linear motion. This piston should be mounted at the end of the inclined surface next to the conveyor belt. The stroke length of this pneumatic piston can be varied according to the need, and tis piston can be easily controlled using a solenoid valve. For informing the system about when a bottle and box are in position to be packed a simple proximity sensor can be used.

Electronic Setup

The conveyor belt can be driven by an AC motor. When the slot housing the box alligns with the Pneumatic piston and the bottle is also in front of the piston, a proximity sensor will detect it (placed in front of the pneumatic piston), and a signal will be sent to a microcontroller, which in turn can stops the conveyor belt. After the conveyor belt stops, the microcontroller will actuate the pneumatic piston with the help of a solenoid/spool valve (depicted by a LED in figure6). When the bottle is pushed inside the box the microcontroller will rotate the servo motor by 120 degrees and the next bottle rolls down. After a specified delay (can be adjusted after experimentation) the conveyor belt is started again and this process is looped. The conveyor belt speed can be easily manipulated by varying the voltage across its terminal. The microcontroller can switch the motor ON/OFF by simply using a relay.

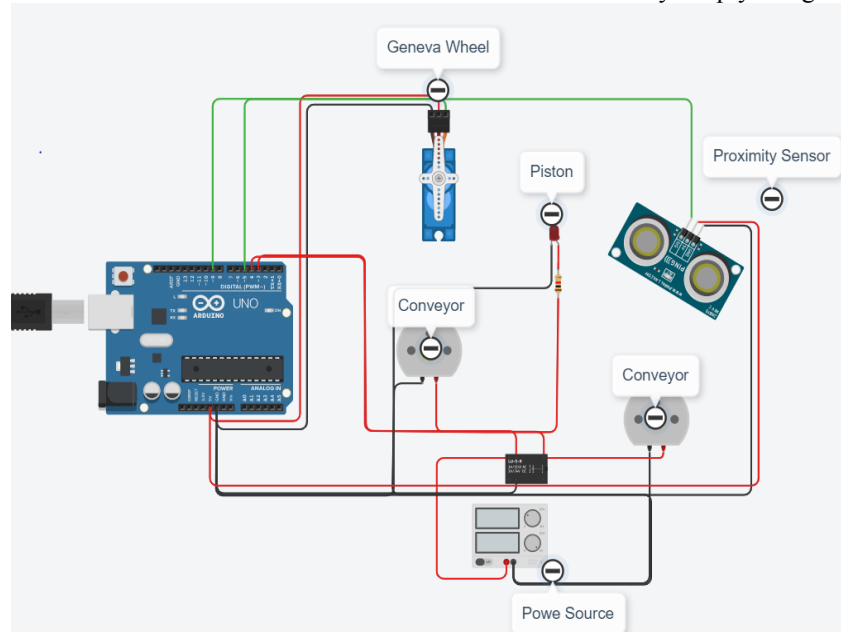

Figure 6:- Electronic Setup.

Future Scope

Firstly, placing the boxes in the slots made for them can also be automated in future designs. Secondly, further designing about how the packed bottles can be placed properly in crates which can be directly shipped, is required. And finally study of optimum motors and a microcontroller is required.

Conclusion:-

The automatic bottle packaging system has high potential. The system developed will make the operation fast. Mainly, it will be a fully autonomous system which is needed in today's world. It will not require any worker. Hence the need of workers is eliminated. The cost and maintenance of this system is very less which will be beneficial for small and medium scale industries. This system will require less area and it will be flexible. It will be a lightweight system which can be moved from one place to another quite easily.

Reference:-

1. Boca, Maria Loredana & Kovac, Pavel & Savković, Borislav. (2017). Model Approach Of Automation Of Bottling And Packaging For Industrial Process Of Bottles. Journal of Production Engineering. 20.69-72. 10.24867/JPE-2017-02-069
2. Hambir, Prajakta & Joshi, Nimish & Karande, Pranav & Kolhe, Amol (2020). Automatic Weighing and Packaging Machine. 10.13140/RG.2.2.25518.87361.
3. Bipin Mashilkar, Praseed Kumar, Amit Chawathe, Vivek Dabhade, Vighnesh Kamath, Gayatri Patil. 2016, Automated bottle filling system.
4. Sina Safinia, Amani Alkalbani, "Use of Recycled Plastic Water Bottles in Concrete Blocks", Procedia Engineering, Volume 164, 2016, Pages 214-221, ISSN 1877-7058.