



ISSN NO. 2320-5407

Journal homepage: <http://www.journalijar.com>
Journal DOI: [10.21474/IJAR01](https://doi.org/10.21474/IJAR01)

INTERNATIONAL JOURNAL
OF ADVANCED RESEARCH

RESEARCH ARTICLE

EXPERIMENTAL STUDY OF HEAT AND MASS TRANSFER IN RANQUE HILSCH VORTEX TUBE.

*M. Chatterjee, S. Mukhopadhyay and P. K. Vijayan
Homi Bhabha National Institute, Mumbai-94, India.

Manuscript Info**Manuscript History:**

Received: 19 May 2016
Final Accepted: 19 June 2016
Published Online: July 2016

Key words:

Vortex tube, Heat transfer, Mass transfer.

***Corresponding Author**

M. Chatterjee.

Abstract

The aim of this work was to experimentally investigate the heat and mass transfer phenomenon in a Ranque Hilsch vortex tube. Experiments in a laboratory scale experimental setup were carried out to generate process data involving parameters such as inlet and outlet volumetric flow rate, temperature and pressure of gas mixture at the inlet and outlet of the Ranque Hilsch vortex tube. Air, considered as a binary mixture of Nitrogen and Oxygen gas was used as working fluid. Gas temperature and composition at inlet, cold outlet and hot outlet were measured. Further the isentropic efficiency and separation factor of the lighter species for a binary separation were calculated. It was observed while isentropic efficiency increased continuously with inlet Reynolds number there was an optimum value of inlet Reynolds number for which maximum separation factor was obtained. Also it was found that thermal and species separations in Ranque Hilsch vortex tube were interrelated.

Copy Right, IJAR, 2016.. All rights reserved.

Introduction:-

A Ranque Hilsch Vortex Tube (RHVT) is a device that generates cold and hot gas from compressed gas. When high-pressure gas is tangentially injected into the vortex chamber via the inlet nozzle, a swirling flow is created inside the vortex chamber. When the gas swirls to the centre of the chamber, it is expanded and cooled. In the vortex chamber, part of the gas swirls to the hot end, and another part exits through the cold exhaust directly. At the hot end of the tube, direction of the swirling gas reverses and moves from the hot end to the cold end. At the hot exhaust, a part of the gas escapes with a higher temperature. At the cold exhaust, the gas has a lower temperature compared to the inlet temperature.

RHVT is a simple and compact low cost device. As this device has no moving part it is maintenance free. The device does not require electrical power and the temperature of hot and cold end fluid can be easily adjusted using the hot end flow control valve. Hence RHVT is regularly used in industry as a spot cooling or heating device. RHVT is also mentioned in literature as a gas species separation device, but very little work on gas species separation with the RHVT has been reported in the literature. Moreover different theories have been proposed by researchers to explain the physics of thermal as well as gas species separation inside the device. But all these theories have their own limitations and contradictions. No unified theory of separation for RHVT is available and hence it is a topic of research interest. The primary aim of the present work was to experimentally investigate the thermal and species separation phenomenon of RHVT and find out their interrelation if any. Experiments in a laboratory scale experimental setup had been carried out to generate process data involving parameters like inlet and outlet volumetric flow rate, temperature, composition and pressure of gas mixture from the RHVT. A Nitrogen and Oxygen gas mixture had been used as working fluid for experimental purpose.

The experimental work on RHVT reported in literature can be broadly subdivided into two categories. They are 1) Research work on heat transfer and 2) Research work on mass transfer. The relevant literature survey has been classified accordingly.

Research work on heat transfer:-

Martynovskii and Alekseev (1956) have experimentally investigated the effect of RHVT design parameters to optimize the energy separation and efficiency. They have observed that the temperature separation increased with increase in inlet pressure. However, the inlet temperature has not been found to affect the temperature separation significantly. Kurosaka (1982) has measured and analyzed the temperature along the axis and near the inlet of the tube, level of sound pressure and the frequency of noise. He has considered the acoustic streaming as the cause of energy separation. He has also introduced an acoustic muffler to improve the performance of the RHVT. Effects of different geometrical and thermo physical parameters on energy separation were experimentally investigated by Saidi and Valipour (2003). They have also investigated the effect of moisture content in air on energy separation by injecting water into the inlet flow and observed the temperature separation and efficiency to decrease with increase in moisture content in the inlet air. Prabakaran and Vaidyanathan (2010) have experimentally studied the effect of orifice diameter and inlet pressure of a RHVT on its thermal performance. Dincer (2011) has experimentally studied the performances of RHVTs under three different situations based on inlet pressure and the ratio of mass flow rate of the cold stream to the mass flow rate of the inlet stream. Avci (2013) has done an experimental study to investigate the effects of nozzle aspect ratio and nozzle number on the performance of a vortex tube. Xue et al. (2013) have done an experimental study of the flow properties in a vortex tube focusing on the thermal separation and energy transfer inside the tube. A description of the flow structure inside the tube has been given, based on the observed three-dimensional velocity, turbulence intensity, temperature and pressure distributions. The gradual transformation of a forced vortex near the inlet to a free vortex at the hot end has been reported in this work.

Research work on mass transfer:-

Linderstrom-Lang (1964, 1966) has observed that short RHVT produces a lower temperature separation and higher species separation. Marshall (1977) has used several different gas mixtures in a variety of sizes of vortex tubes and confirmed the effect of the gas separation reported by Linderstrom-Lang (1966). A critical inlet Reynolds number has been identified at which the separation was a maximum. Cockrell (1998) has reported use of vortex tubes for gas liquefaction and mixture separation. Manohar and Chetan (2002) have used a vortex tube for separating Methane and Nitrogen from a mixture and found that there was partial gas separation leading to a higher concentration of methane at one exit in comparison to the inlet and a lower concentration at the other exit.

Experimental setup and methods:-

The schematic diagram of the RHVT test facility is shown in figure 1. The RHVT was thermally insulated and three RTDs measuring temperatures T_1 , T_2 and T_3 were connected to the inlet, cold outlet and hot outlet respectively for measuring the gas temperature. Three more RTDs measuring temperatures T_4 , T_5 and T_6 were connected to the horizontal tube of the RHVT at equal interval to measure the skin temperature. Both the cold and hot outlets were connected with two horizontal cylindrical chambers in order to obtain mixing cup temperatures at the outlets. Three pressure gauges were connected to the inlet, cold outlet and hot outlet respectively for measuring the gas pressure. Compressed air from the air compressor passed through a dehumidifier and became moisture free. This high pressure air entered the RHVT inlet through a rotameter and the inlet volumetric flow rate was measured from the rotameter reading. Similarly the volumetric flow rates of air coming out from the hot and cold outlets of the RHVT were measured from the two rotameters attached to these outlets respectively. Pressure and volumetric flow rate of air entering the RHVT was controlled by a control valve fitted in the inlet line. Two sample collection lines were

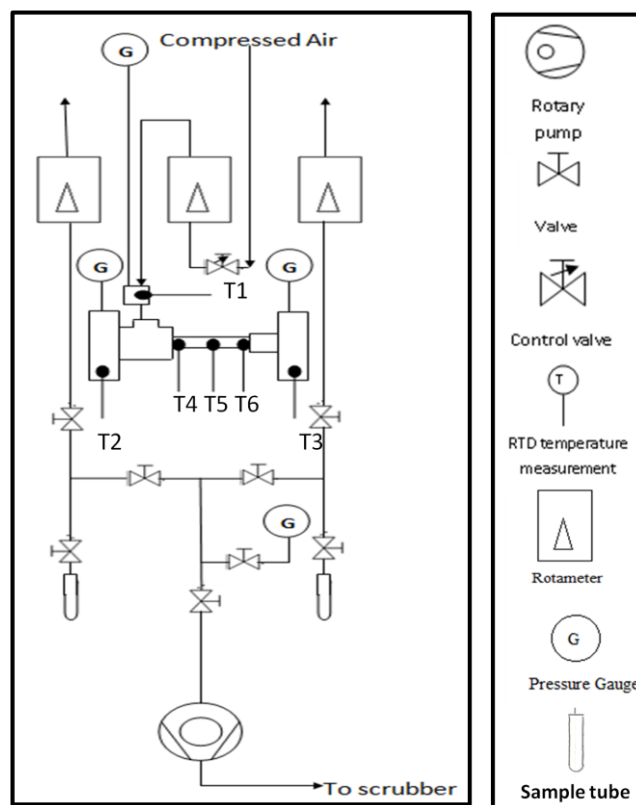

Fig 1:- Schematic diagram of experimental setup.

connected to the hot and cold ends of the RHVT in order to collect gaseous sample for mass spectrometric analysis. These two lines were connected with two sample tubes located at the end of the lines as shown in the schematic diagram. While sampling, both the sample tubes were isolated from the main system by closing the two isolation valves and then connected to a rotary pump. Thus the sample tubes were evacuated. Then the vacuum pumping lines were closed. Next the sample tubes were connected with the main system by opening the two control valves and gas samples flowing out of the hot and cold end of the RHVT entered the respective sample tubes connected to the lines due to pressure difference. Finally the valves situated upstream of the test tubes were closed and detached along with the tubes from the sample lines. Thus the samples became ready for mass spectrometric analysis which was carried out using a HIDEN make Residual Gas Analyzer (RGA) Mass Spectrometer.

The principle component of the RHVT is the vortex generator, which is an interchangeable, stationary part that can regulate the volume of compressed air, altering the air flows and temperature ranges that can be produced with the vortex tube. The capacity of gas that can be handled by a vortex generator depends on the size and number of the angular slots engraved into it, while the direction of the air flow depends on the angle of the slots. Two different FRIGID-X vortex generators namely 10H and 40H has been used for experimentation with a FRIGID-X medium size H-series vortex tube. The specification of the vortex generators are given in table 1 (NEX FLOW catalogue, 2009).

Table 1: Specification of Vortex generator used for experiments

Model	Model no.	Inlet flow rate (ft ³ /min)	Inlet pressure (bar)	Cooling capacity (watt)
10H	50010H	10	6.9	214
40H	50040H	40	6.9	849

Results and Discussions:-

If we consider the RHVT system as adiabatic and inlet gas at high pressure (P_i) expands to atmospheric pressure (P_a) at the outlet, then isentropic efficiency η_{is} of RHVT is defined as

$$\eta_{is} = \frac{T_1 - T_2}{T_1 \left(1 - (P_a/P_1)^{\left(1 - \frac{1}{\gamma} \right)} \right)} \tag{1}$$

Also the separation factor (alpha) of the lighter species for a binary separation is defined by

$$\alpha_{13} = \frac{1 - N_3}{N_3} \frac{N_1}{1 - N_1} \tag{2}$$

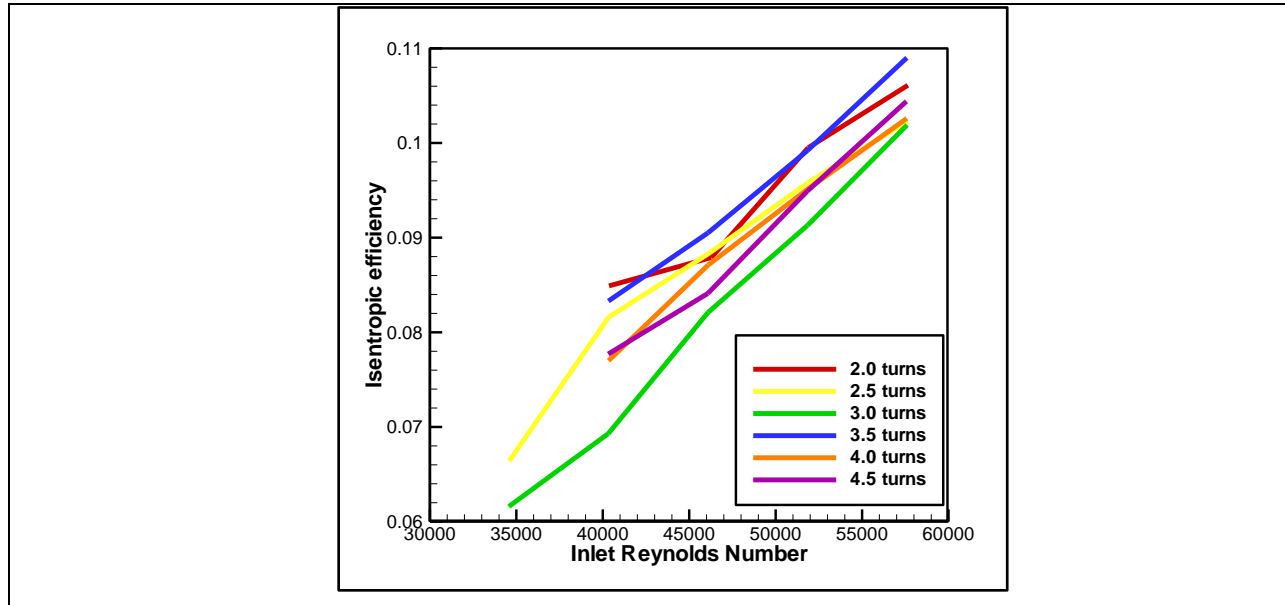

Fig 2a:- 10H generator :Inlet Re Vs. Isentropic efficiency for different hot end screw openings

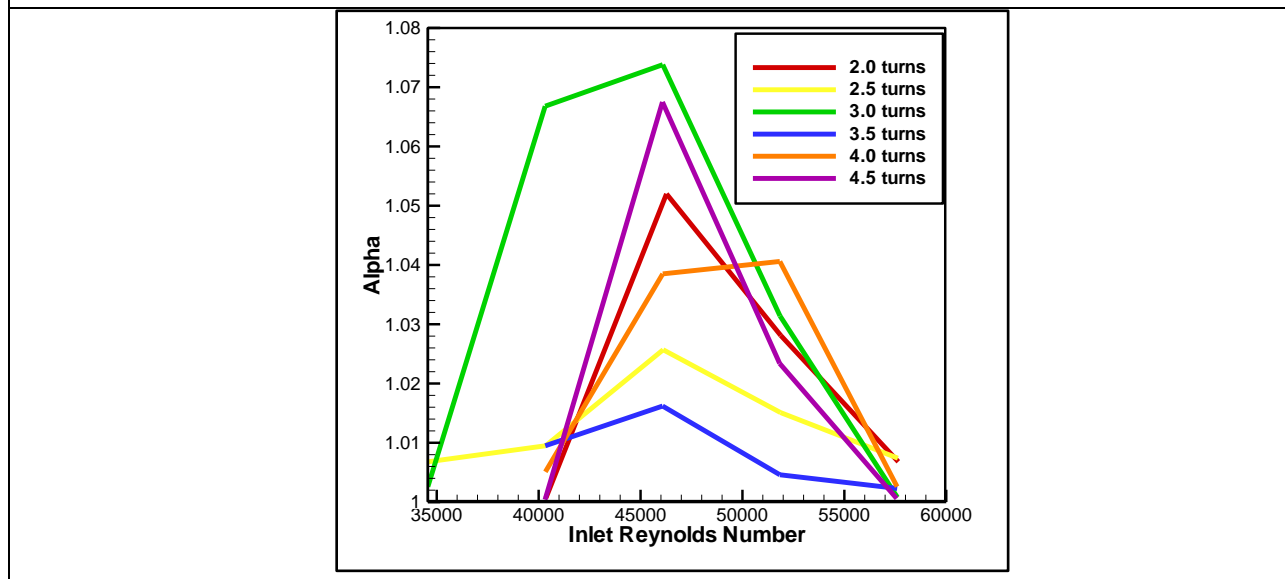

Fig 2b:- 10H generator :Inlet Re Vs. separation factors for different hot end screw openings

In the present work inlet Reynolds number (*Re*) was varied for different levels of openings (1.5 turns to 4.5 turns for 40H generator and 2.0 turns to 4.5 turns for 10H generator) of the hot end control valve. Here one full turn is equal to 360° opening of the hot end control valve. The isentropic efficiency and separation factor had been plotted with respect to inlet Reynolds number as shown in figure 2a and 2b for 10H vortex generator and figure 3a and 3b for 40H vortex generator respectively.

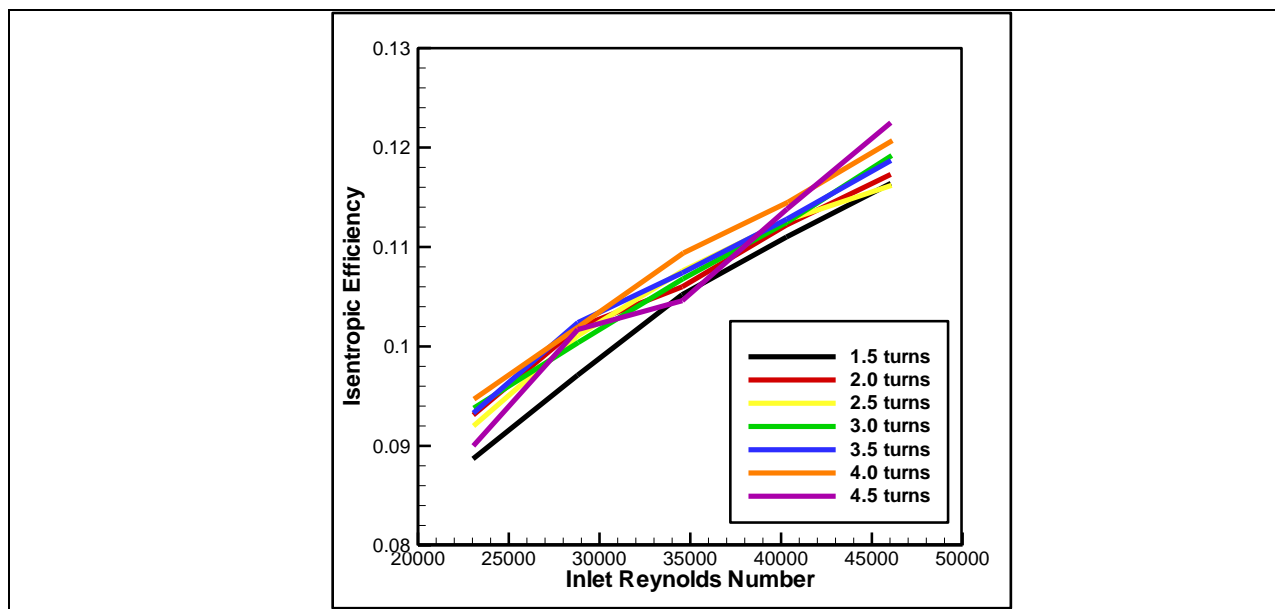

Fig 3a:- 40H generator :Inlet Re Vs. Isentropic efficiency for different hot end screw openings

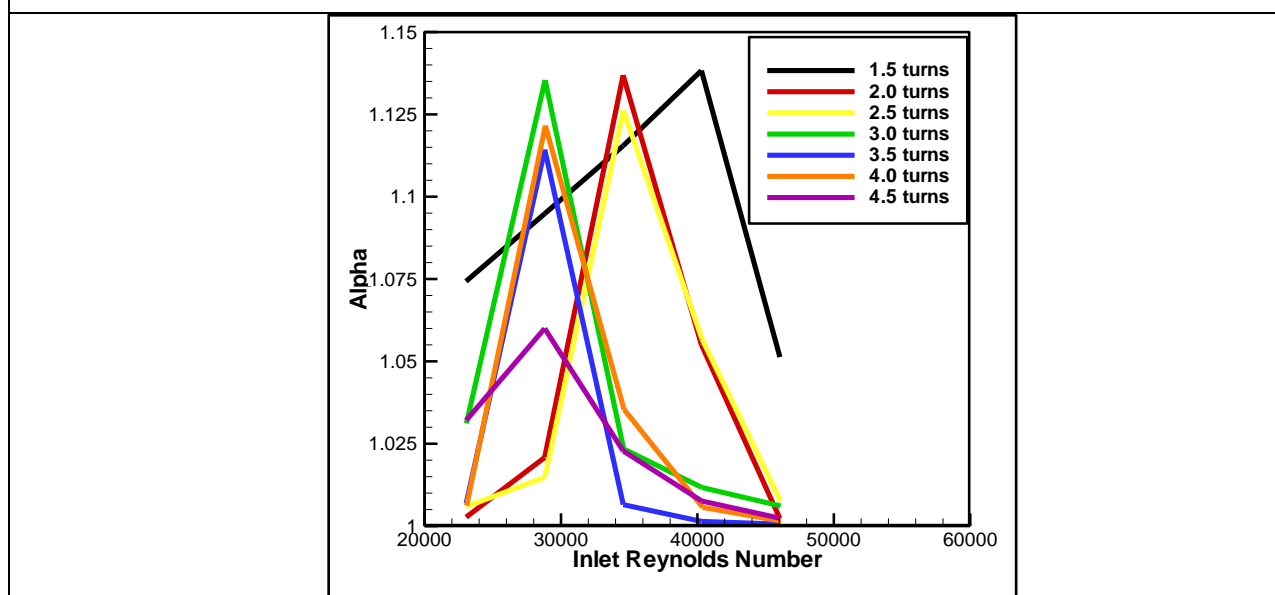

Fig 3b:- 40H generator :Inlet Re Vs. separation factors for different hot end screw openings

It was observed from the above graphs that while isentropic efficiency increased continuously with inlet Reynolds number there was an optimum value of inlet Reynolds number for which the separation factor became maximum. This was due to the onset of turbulence at this Reynolds number that lead to mixing which reduced mass separation at higher values of the inlet Reynolds number. This optimum value also shifted to lower values of inlet Reynolds number with increasing values of hot end screw openings.

Further the thermal and species separation in the RHVT had been compared. The thermal separation in the RHVT has been defined as follows

$$Thermal\ separation = \frac{T_2 / (T_1 - T_2)}{T_3 / (T_3 - T_1)} \tag{3}$$

In figure 4 a, b and c thermal separation as defined in equation (3) and separation factor (alpha) as defined in equation (2) were plotted against different inlet Reynolds number for the vortex tube with 10H vortex generator. These values were plotted for three different hot end screw opening values of 2.0, 3.0 and 4.0 respectively. Similar data had been plotted for vortex tube with 40H vortex generator in figure 5 a, b and c. It was seen from the graphs that -

- Optimum values of thermal separation and species separation occurred at same inlet Reynolds number range for each values of hot end screw opening.
- It could also be seen that overall thermal separation decreased with increasing hot end screw opening.
- The overall values of both separation factor and thermal separation increased in 40H vortex generator compared to 10H vortex generator.
- It could also be seen that as the basis of heat and mass transfer was same (i.e. axial vortex flow inside the tube), these two phenomenon were interrelated and influenced each other.

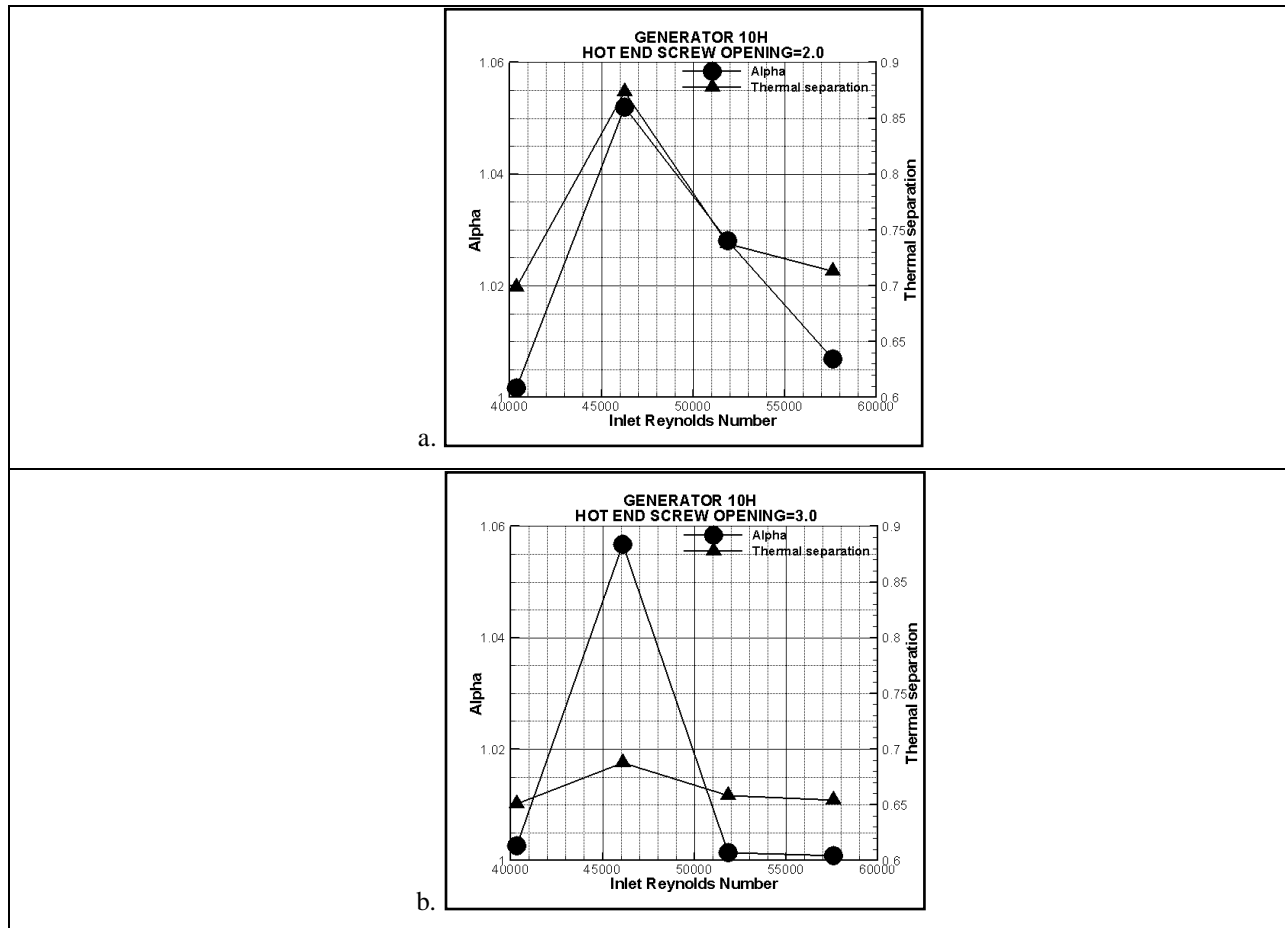

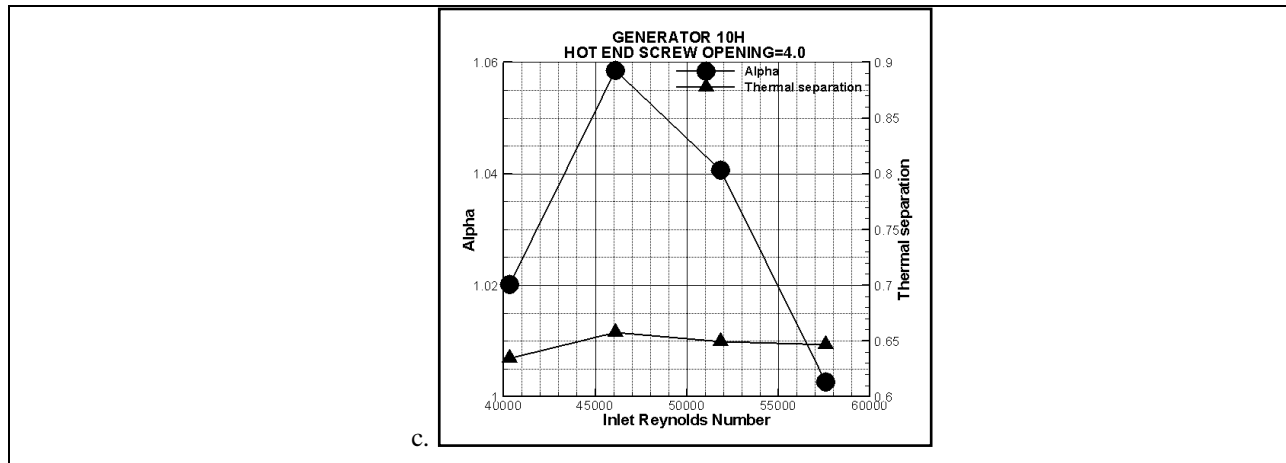
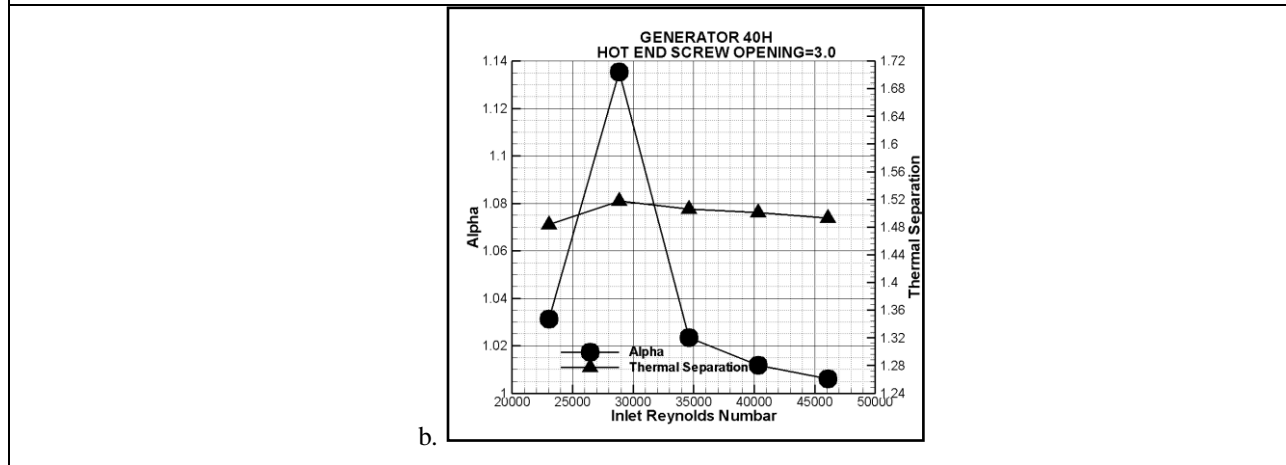
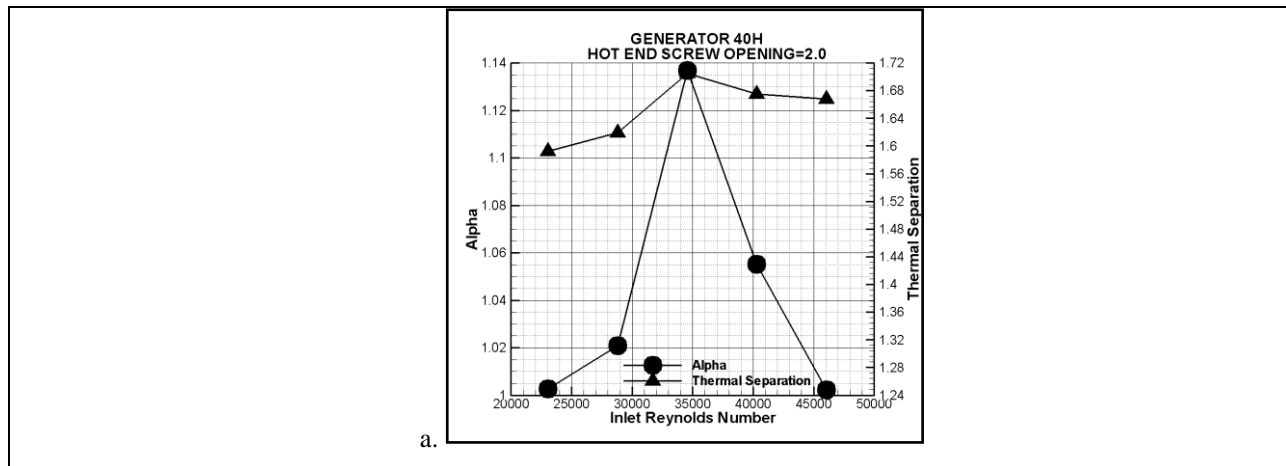
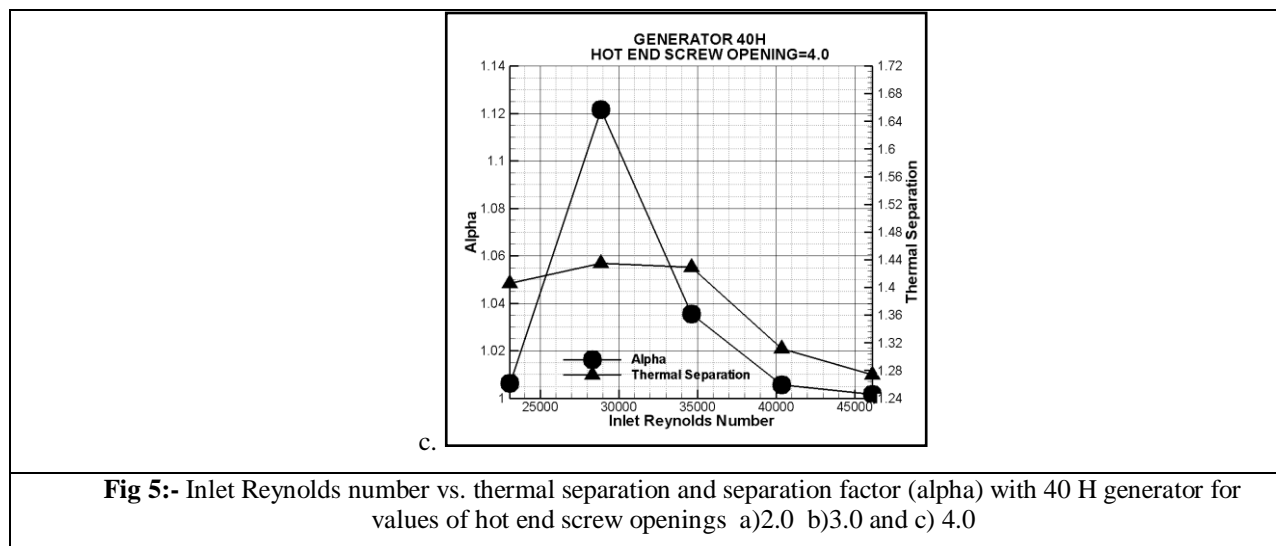

Fig 4:- Inlet Reynolds number vs. thermal separation and separation factor (alpha) with 10 H generator for values of hot end screw openings a)2.0 b)3.0 and c) 4.0





Nomenclature:-

N_1	Mole fraction of heavier species at inlet
N_3	Mole fraction of heavier species at hot outlet
P_1	Inlet pressure (Pa)
P_a	Atmospheric pressure (Pa)
Re	Reynolds number
T_1	Inlet temperature (Kelvin)
T_2	Cold outlet temperature (Kelvin)
T_3	Hot outlet temperature (Kelvin)
α_{13}	Separation factor, alpha
γ	Ratio of specific heat
η_{is}	Isentropic efficiency

Conclusion:-

Thermal and species separation results obtained from experimental studies with a Ranque Hilsch vortex tube using air as a binary mixture of Nitrogen and Oxygen has been presented. The following conclusions were drawn

- Within the experimental range of Reynolds number, while isentropic efficiency increased continuously with inlet Reynolds number there was an optimum value of the Reynolds number for which the separation factor reached its maximum. This is due to the onset of turbulence at this Reynolds number that lead to mixing which affected mass separation adversely.
- The mechanism of species and thermal separation were interrelated.
- Thermal and species separation depended on vortex generator size, inlet Reynolds number and hot end screw opening.

References:-

1. Avci, M., (2013), "The effects of nozzle aspect ratio and nozzle number on the performance of the Ranque-Hilsch vortex tube", Applied Thermal Engineering 50, pp. 302-308.
2. Cockerill, T., (1995). "Thermodynamics and Fluid Mechanics of a Ranque-Hilsch Vortex tube", Masters thesis, University of Cambridge, England.
3. Dincer, K., (2011), "Experimental investigation of the effects of threefold type Ranque-Hilsch vortex tube and six cascade type Ranque-Hilsch vortex tube on the performance of counter flow Ranque-Hilsch vortex tubes", International journal of refrigeration , 34, pp. 1366 – 1371.
4. Kurosaka, M. (1982), "Acoustic streaming in swirling flow and the Ranque Hilsch vortex tube effect", J. Fluid Mech. 124, pp. 139-172.
5. Linderstrom-Lang, C.U., (1964) , "Gas separation in the Ranque-Hilsch vortex tube", Int. J. Heat Mass Transfer 7, pp. 1195-1206.

6. Linderstrom-Lang, C.U., (1966), "Gas separation in the Ranque-Hilsch vortex tube model calculations based on flow data", Riso report, Denmark.
7. Marshall, J., (1977), "Effect of Operating Conditions, Physical Size, and Fluid Characteristics on the Gas Separation Performance of a Linderstrom-Lang Vortex Tube", *Int. J. Heat Mass Transfer*, Vol. 20, pp. 227-231.
8. Martynovskii, V.S., Alekseev, V.P., (1956). "Investigation of the vortex thermal separation effect for gases and vapours", *Tech. Phys.* 1, pp. 2233-2243.
9. Manohar, R., Chetan, R., (2002), "Enrichment of methane concentration via separation of gases using vortex tubes", *J. Energy Eng.* 128, pp. 1-12.
10. NEX FLOW product catalogue, (2009), NEX FLOW air products corp., pp J-3.
11. Prabakaran, J., Vaidyanathan, S.,(2010), "Effect of orifice and pressure of counter flow vortex tube", *Indian Journal of Science and Technology*, Vol. 3 No. 4, pp. 374-376.
12. Saidi, M.H., Valipour, M.S., (2003.) "Experimental modelling of vortex tube refrigerator. *Appl. Therm". Eng.* 23, pp. 1971-1980.
13. Xue, Y., M. Arjomandi and Kelso R., (2013), "Experimental study of the thermal separation in a vortex tube", *Experimental Thermal and Fluid Science* 46,pp. 175–182.