



ISSN NO. 2320-5407

Journal homepage: <http://www.journalijar.com>

Journal DOI: [10.21474/IJAR01](https://doi.org/10.21474/IJAR01)

INTERNATIONAL JOURNAL
OF ADVANCED RESEARCH

RESEARCH ARTICLE

BIOMETRIC WRIST BAND.

Madhura M. Jamkhedkar¹, Kaustubh S. Jawalekar¹, Sayali S. Gawande¹ and Prof. Wrushali M. Mendre².

1. U.G. student Department of Electronics and telecommunication, SKNCOE , Savitribai Phule Pune University , Pune, India.
2. Assistant professor, Department of Electronics and telecommunication, SKNCOE , Savitribai Phule Pune University , Pune, India.

Manuscript Info

Manuscript History:

Received: 19 March 2016
Final Accepted: 18 April 2016
Published Online: May 2016

Key words:

Android, Wearable, BLE, Calories, Pulse-count, Body-temperature.

*Corresponding Author

Madhura M. Jamkhedkar.

Abstract

This article aims to present research information regarding designing of a wearable biometric device that will keep an account of heart beats, body temperature and the calories burnt by the respective user. The display will be given on an android application on user's cell. Bluetooth low energy (BLE) technology will be used for communication between the device and the application. The purpose behind designing of this device is to keep an account of user's health parameters. The Bluetooth enables wireless communication between the device and the application. Biometric band is a device which tracks user's pulses, calories and body temperature. The device is supported by a small battery, a Bluetooth tag and a memory. The data will be acquired with the help of pulse count detector, Thermistor and accelerometer.

Copy Right, IJAR, 2016,. All rights reserved.

Introduction:-

Human being of 21st century is very conscious about his lifestyle, fashions, good looking and last but not the least Health. Every other person is working out in gym or exercising on grounds or getting trained in fitness programs. Everyone wants fitness for his long life. Due to the technological development, we can have systems for analysis of our exercises or workouts. These systems will help us as well as doctors and trainers for maintaining tracks of our routine life. Thus, each and every person wants a system that will help them to keep an account of their very essential body parameters such as body temperature, pulse count, calories burnt or gained etc. There are more parameters, users want to analyze such as blood pressure, sugar level, water content etc. These systems must be easy to handle, should be having long life, must consume less power and must be very easily readable.

Hence a wearable device is needed which will measure these body parameters and keep track of some of earlier readings in its memory. The display of the system must be large enough so that elder people will not find any problem in reading. Thus, to keep an account of pulse count, body temperature and calories burnt by a user at one platform is a generous need of today's era. The Biometric Wrist Band will measure all the above parameters and will display the same on an android application. The Biometric wrist band is a portable device which is easy to carry and light weight. Biometric wrist band is designed with a circuit having temperature sensor, pulse counter and accelerometer kept in same package. It is a device which helps user to have an account of his health parameters along with the readings at the regular interval of time.

The display of the readings is provided on android based smart phones. A dedicated application is designed for the purpose. The display on application reduces the size of the device, weight of the device and thus increases the portability. This enables ease in reading and reduces the power requirement on device side.

For the communication between the device and the application Bluetooth low energy is used. BLE enables wireless communication. This reduces hardware on device side and ultimately decreases power consumption and provides faster communication.

Reduction in hardware and wireless communication because of Bluetooth makes Biometric wrist band cost effective. This feature makes biometric wrist band appropriate for a common man.

Literature survey:-

A] History:-

a) Wearable devices:-

The first ever wearable device we used was the calculator watch in 1980s. It was one of the life changing invention for humans. As the use of mobiles started increasing in late 90s, humans were demanding smaller mobiles and more functions. To satisfy this requirement, we invented android and Bluetooth technologies and in 2008 Ilya Fredman incorporated a hidden camera in her ear-rings.[1]

This incidence changed the whole definition of wearable. People began to think of turning our day to day life wearable things for some functioning like camera, small computations etc. There onwards companies like twitter, apple, ZED-fone used normal digital wrist watches for sending and receiving messages and new era was begun. Now a days, apple watch, Sony watch, Samsung watches are in demand for sending and receiving mails, calls, messages, giving information about weather and analyzing health parameters.[2]

b) Wearable devices used for maintaining health parameters:-

The first ever wearable device which will track health parameters was brought into the market by Fit bit in 2009. The device used to track calories burnt or gained by a user during his activity. After that Apple watch incorporated this function and provided a wrist watch which will measure calories. Apple watch included a memory for some of the previous readings.[3]

Around 2010-2013, many of the companies brought their wearable product for measuring body temperature, displaying pulse count, calories etc. But all these devices were dedicated for only one functioning. In 2014, Fit bit launched a wrist band that shows body temperature, pulse count, calories, timing, weather conditions, location etc.[4]

B] Selection of components:-

a) Selection of Microcontroller:-

The basic criteria for selection of microcontroller is the microcontroller having inbuilt Bluetooth connectivity. There are several chips in market which provide Bluetooth connectivity: Ex. Nordic, TI CC2640, PSOC etc.

The basic idea behind selecting CC2640 microcontroller was the requirement of built in BLE which is able to communicate with the android application using Bluetooth.

Features of CC2640:-

1. ARM Cortex-M3 processor core
2. 2.4 GHz RF Transceiver Compatible With *Bluetooth* Low Energy (BLE) 4.1 specification
3. On-chip memory
4. Advanced serial integration
 - i. Universal asynchronous receiver/transmitter (UART)
 - ii. Inter-integrated circuit (I2C) module
 - iii. Synchronous serial interface modules (SSIs)
 - iv. Audio interface I2S module
5. 12-Bit ADC, 200-ksamples/s, 8-Channel Analog MUX
6. All Digital Peripheral Pins can be routed to any GPIO
7. 128KB of In-System Programmable Flash
1. 8-KB SRAM for Cache

b) Selection of Temperature Sensor:-

The basic criteria for selection of temperature sensor is to select a sensor that will consume less power and takes less current for working. Thus, we elected to use Thermistor over RTDs. RTDs require much more power compared to Thermistor for working.

c) Selection of Accelerometer:-

Calorie sensors are nothing but Accelerometers, magnetometers or accelerometer and magnetometer together. Here, the circuit requires 3-axis accelerometer. The accuracy of accelerometers is decided in terms of 'g'. There are various accelerometers such as 2g, 4g, 6g, 8g etc.

There are various accelerometers available in market such as MMA8652FC, MMA8652Q and LIS2DH etc. All of these provide 2g to 6g range and consume less power.

The accelerometer LIS2DH is ultra low power, high performance, three axis, $\pm 2g/\pm 4g/\pm 8g/\pm 16g$ dynamically selectable, full scale accelerometer.

Feature of LIS2DH:-

1. Wide supply voltage, 1.71 V to 3.6 V
2. Independent IOs supply (1.8 V) and supply voltage compatible
3. Ultra low-power mode consumption down to $2\mu A$
4. $\pm 2g/\pm 4g/\pm 8g/\pm 16g$ dynamically selectable full scale
5. I2C/SPI digital output interface
6. 2 independent programmable interrupt generators for free-fall and motion detection
7. 6D/4D orientation detection
8. "Sleep to wake" and "return to sleep" function
9. Freefall detection
10. Motion detection
11. Embedded FIFO

d) Pulse count sensor:-

MAX30100 IC is pulse Oximeter and heart rate sensor IC can be used in wearable health devices.

Features of MAX30100:-

1. Integrated LEDs, Photo Sensor, and High-Performance Analog Front –End
2. Ultra-Low-Power Operation Increases Battery Life for Wearable Devices
3. Advanced Functionality Improves Measurement Performance

Block diagram:-

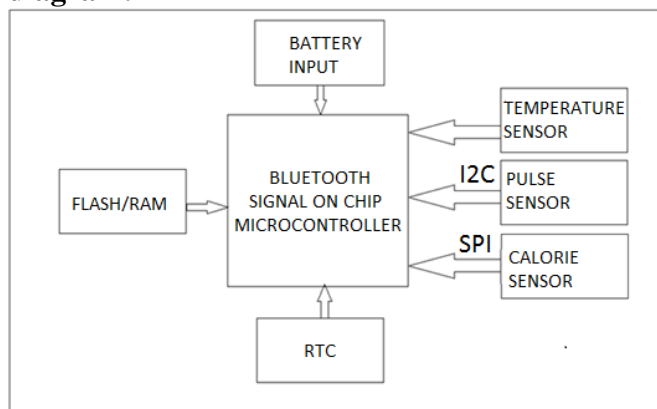

Block diagram description:-

Biometric wrist band has the CC2640 microcontroller which is the heart of the device. CC2640 is connected to Thermistor i.e. temperature sensor, LIS2DH accelerometer i.e. calorie sensor and MAX30100 IC i.e. pulse count sensor. CC2640 communicates with the android application on android based smart phone. This feature is used for displaying the readings on the application.

Thermistor is connected to one of the GPIO of CC2640. LIS2DH is connected through SPI to microcontroller. MAX30100 is connected to CC2640 using I2C serial communication.

Methodology:-

A] Device side:-

a) Description:-

Biometric wrist band is a wrist wearable device which is being developed for measuring body parameters. The CC2640 microcontroller is used which is Bluetooth Low Energy (BLE) compatible and able to communicate with other Bluetooth Low Energy (BLE) devices. The programming of CC2640 is done in IAR embedded workbench version 7.0. The programmer board used to program CC2640 is SmartRF06. The programming of CC2640 with LIS2DH is done in IAR. Accelerometer gives the position in terms of x-y-z coordinates. The change in the values of x-y-z coordinates the microcontroller is interrupted by accelerometer. After interruption microcontroller sends readings to the android application. Thermistor is connected to one of the GPIO of microcontroller. The readings are further given to build in ADC of microcontroller which provides digital readings to microcontroller and further to android application. The Thermistor has negative temperature coefficient (NTC). The human body temperature range is 25 degree Celsius to 42 degree Celsius. Thus, increase in body temperature will decrease the resistance. CC2640 is connected to pulse count sensor i.e. MAX30100. It is a integrated pulse Oximeter and heart rate monitor sensor. I2C interface is used for connection between CC2640 and MAX30100. The result will be displayed on android application.

b) Flow chart:-

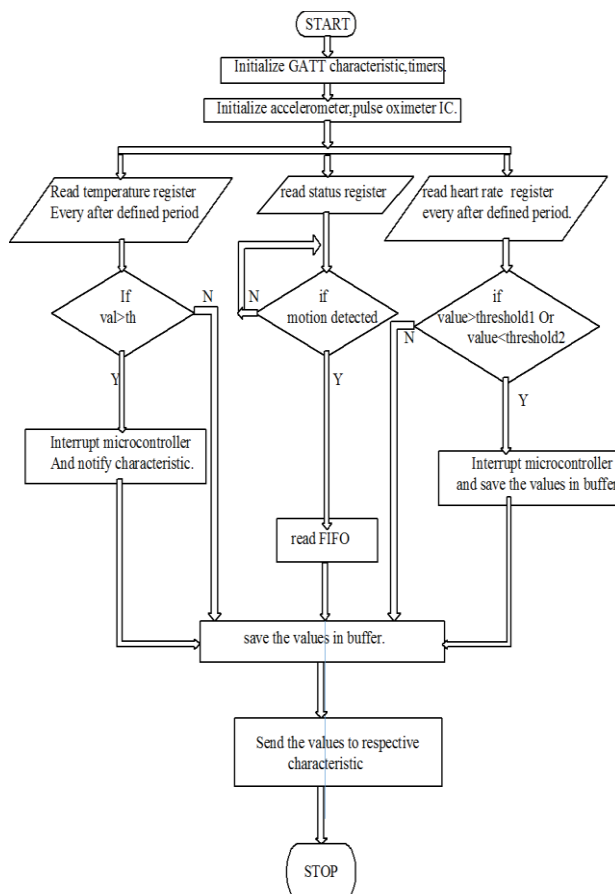

B] Android application:-

a) Description:-

An Android application is being developed to display the readings on android based smart phone. This application communicates with the device using Bluetooth. The application is written using java language.

Initially, eclipse IDE was used for development of the application. Google then has taken away the support for the eclipse IDE for android development.[6] Thus, the application is developed in Android studio. 'www.developer.android.com' is an official website which guides for porting the codes from eclipse to the studio. The actual coding is done in 3 parts. First is initialization of wireless (Bluetooth) connection with the device. Then establish the connection of the phone to the device with the help of Bluetooth. Then read the Characteristics of specific attributes written on the device, where the actual result is obtained.

b) Flowchart:-

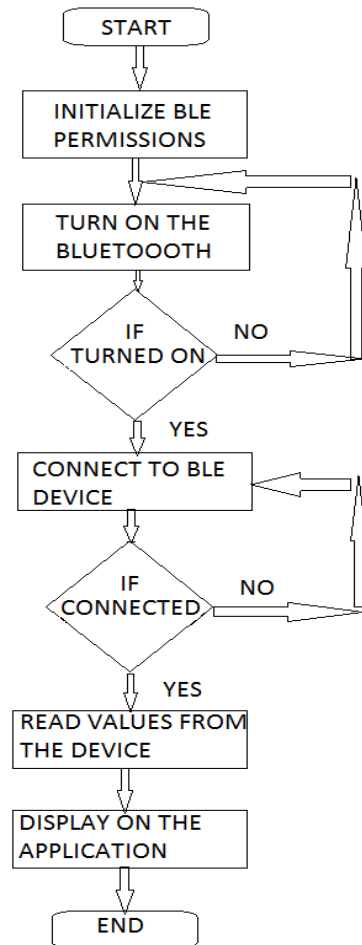

Future scope:-

The biometric wrist band will currently be measuring body temperature, pulse count and calories burnt by the user. The parameters can be varied or increased or decreased further according to consumer's requirements. Many other parameters such as blood pressure can be included in the system. The display can be given on the device itself and the provision of watch and calendar can be done there itself.

The biometric wrist band currently can be used only with the smart phones based on android operating system. In future the IOS and Windows based application will be developed and the band will be compatible with all 3 operating systems of smart phones.

The communication between the device and the application can be done using Wi-Fi technology instead of Bluetooth.

Conclusion:-

A wearable device will be developed by using Bluetooth signal on chip microcontroller. This device will be used to track the changes occurring in various health parameters such as heart beats, calories and body temperature.

The device will be power efficient. It should consume less memory. Being a wireless device it requires less hardware. Thus, it will be less bulky. It will be more cost effective due to reduced power and less memory. The very essential features and affordability will enable maximum number of people become health conscious.

Acknowledgement:-

We would like to extend our acknowledgment to certain people who have been very helpful and without whom this project could not have been completed. We wish to express our gratitude to **Dr A. V. Deshpande** principal of Smt. **Kashibai Navale College of Engineering, Vadgaon, Pune** for giving us permission to carry out this project. We would also like to thank **Maven Systems pvt. Ltd.** For their support, guidance and help in all possible ways. We express our profound gratitude to internal project guide **Prof. Wrushali M. Mendre** and **Prof (Dr.) S. M. KOLI**, project coordinator for their guidance due to which our difficulties and questions were cleared leading to the development of this project. We would like to thank our Head of department **Prof (Dr.) S. K. Jagtap** for the tremendous inspiration she has given to us. We are also thankful to the staff of our **E&TC** department for their valuable support and all others who directly or indirectly contributed for the success of our project.

References:-

1. https://en.wikipedia.org/wiki/Wearable_technology#History
2. https://en.wikipedia.org/wiki/Wearable_technology#History
3. https://en.wikipedia.org/wiki/Wearable_technology#History
4. E. https://en.wikipedia.org/wiki/Wearable_technology#History
5. C. J. Kaufman, Rocky Mountain Research Lab., Boulder, CO, private communication, May 1995.
6. developer.android.com/tools/help/adt.html