



Journal Homepage: - [www.journalijar.com](http://www.journalijar.com)  
**INTERNATIONAL JOURNAL OF  
 ADVANCED RESEARCH (IJAR)**

Article DOI: 10.21474/IJAR01/6123  
 DOI URL: <http://dx.doi.org/10.21474/IJAR01/6123>



### RESEARCH ARTICLE

## FREQUENCY REGULATION WITH VANADIUM REDOX FLOW BATTERY STORAGE SYSTEM IN SMART GRID.

L. Sathyarani<sup>1</sup> and Dr. S. Jeyadevi<sup>2</sup>.

1. PG Student/Electrical and Electronics Engineering, Kamaraj College of Engineering and Technology, Virudhunagar, Tamilnadu.
2. Professor/ Electrical and Instrumentation Engineering, Kamaraj College of Engineering and Technology, Virudhunagar, Tamilnadu.

### Manuscript Info

#### Manuscript History

Received: 21 October 2017  
 Final Accepted: 23 November 2017  
 Published: December 2017

#### Keywords:-

Energy management system, Vendium Redox flow Battery (VRBF), Smart Grid, Frequency Regulation.

### Abstract

Energy storage systems are prime part for demand load management in the smart grid. Electrochemical energy storage system is one among them to improve the storage of energy. Since technologies like sodium-sulphur, lithium-ion and redox flow batteries have been developed to support grid application. In which the Vanadium Redox Flow Battery (VRFB) can able to reach 80% efficiency and have a fast time response. The International Electrochemical Commission (IEC) recommends industry to develop their storage management systems which allow use of a single storage system for not just one but many of the applications. Controllers and management systems are required which function independently of the types of batteries being controlled. The control technology should function even when the applications belong to different scenarios. Vanadium redox flow batteries are a promising option to mitigate the overall cost, the number of charging cycles, the depth of discharge and energy density. This study presents a modeling of VRFB based storage device along with a controller. The effectiveness where prove under different scenarios.

Copy Right, IJAR, 2017.. All rights reserved.

### Introduction:-

EU imports 53% of its vitality at a cost of around EUR 400 billion, which makes it the biggest vitality merchant on the planet [2]. Six Part States rely on upon a solitary outer provider for their whole gas import and hence remain excessively defenseless, making it impossible to supply stuns. The objectives set by the Energy Union Package [2] and the constant execution of Renewable Energy Sources (RES), posture new sorts of difficulties to the power matrix in its way to turn into "more intelligent". Not at all like conventional unified era plants, RES might be found wherever along the matrix, maybe nearer to the stack focuses they serve, scattered over the system, even in remote seaward areas or in secluded situations. Such key changes in the design and controllability of the lattice call for shrewd and proficient power transmission and conveyance systems. Keeping up the harmony amongst era and utilization in various time periods (from a few moments for framework soundness to a few hours for overhauling the fluctuating interest) is key for guaranteeing power framework security. Expanding the utilization of conventional reinforcement fossil-fuelled offices on the network (either for giving turning save or to taking care of pinnacle demand), would diminish the natural advantages that RES are planned to

**Corresponding Author:- L.Sathyarani.**

Address:- PG Student/Electrical and Electronics Engineering, Kamaraj College of Engineering and Technology, Virudhunagar, Tamilnadu.

bring. Vitality stockpiling is thus turning into a key part of brilliant matrices defeating a large number of these difficulties. In any case, matrix associated vitality stockpiling introduced limit is still around 140–150 GW overall [3], of which 99% are pumped hydro frameworks (PHS) [3].

At the point when alluding to RES, where supply does not take after the request, vitality stockpiling frameworks (ESS) have been utilized to move such supply. Be that as it may, as far as lattice control adjustment, its utilization is definitely not so broad. Sunlight based or wind control inconstancy are for the most part not of concern when the infiltration level is under 10% of the aggregate stack [4]. In such situations, the present strategies for adjusting era also, load are adequate to adjust for RES control changeability. Be that as it may, when the infiltration level increments to a huge segment of the aggregate load (>20%), the control limit of a controlled range will decrease. This happens in light of the fact that RES don't offer such administrations (unless working abridged). Along these lines, the more RES in the framework, the more strained are the routine plants that offer programmed recurrence direction. For load era RES fluctuation is an issue, since it requires extra turning saves in the time span of a few minutes, and may require a warm armada with sufficient increase/down rates for the time casing of hours [4].

Capacity frameworks have been viewed as an awesome potential to give auxiliary administrations, possibly supplanting turning stores, or control administrations for voltage and recurrence. So far, numerous advancements have been concentrated on for various purposes, and these can be separated in five classifications: Chemical (Hydrogen and Synthetic Natural Gas), Electrical (Capacitors and Super Conducting Magnetics) Electrochemical (lead-acid, Na-S, Ni-Cd, Li-particle, and stream batteries Vanadium, Za-Br), Mechanical (Flywheels, packed air, Pumped hydro) and Thermal (ex: Heat, Molten salt) [5]. In the gathering of auxiliary administrations gave in the open market administration of the network, the recurrence direction benefit has been recognized as the most astounding need [5,6]. Generally recurrence control is for the most part given by sloping (up as well as down) of era resources. Power stockpiling has the ability of giving this administration by acting in millisecond.

As of late, superior electrochemical vitality stockpiling advances, for example, sodium-sulphur, lithium-particle, and framework applications. Electrochemical capacity advancements offer a plausibility to relieve the disadvantages brought about by RES and load inconstancy with a number of uses, for example, control quality change, top stack administration or voltage and recurrence control. In spite of progresses in electrochemical vitality stockpiling innovation, batteries have just been sparingly actualized for matrix administrations reason. This reality can be ascribed to the high cost of existing battery frameworks what's more, instability of their long haul unwavering quality. Also, there is vulnerability about the exact financial estimation of battery vitality stockpiling in framework level applications. There are basically two purposes behind this instability. The primary reason needs to do with the specialized qualities of every framework as there is no innovation to fit all needs. Some are less costly however not versatile, other have high vitality thickness yet are more costly, some others have low vitality thickness and are lower in cost yet have restricted lifetime. The second reason needs to do with the high starting expense of generally innovations furthermore, their long payback expected period. A multi-capacity of such frameworks is protected as attractive [7–9] keeping in mind the end goal to moderate framework's high cost and diminishing the danger of the venture. Be that as it may, for some batteries, their more concentrated utilize may diminish their lifetime relying upon the innovation. As of late, among numerous capacity innovations, the Vanadium Redox Flow Battery (VRFB) has drawn much consideration. Its utilization is being shown in a number of activities in different areas, demonstrating that the VRFB innovation can be effectively misused. Applications differ in sizes from a few kilowatts to a few megawatts [10] and business arrangements are officially accessible.

In any case, there are just restricted studies tending to the specialized execution of a VRFB, particularly in giving subordinate administrations. Moreover, regardless of the possibility that Vanadium may introduce itself as a promising answer for vitality stockpiling, it should likewise be concentrated on concerning consistence with appropriate measures and primary execution obstructions must be caught on. This study gives such an appraisal, introducing a framework vitality stockpiling model, utilizing a displayed VRFB stockpiling gadget to perform recurrence direction what's more, pinnacle shaving capacities. The study shows the improvement of a controller to give a net power yield, empowering the framework to constantly perform both capacities.

#### **Literature Survey:-**

The paper proposes vanadium redox flow battery model and to regulate the primary frequency response according to different time frames .grid connected energy storage systems are providing ancillary services to electricity networks

and in development of smart grids. Inverter controller provides a net power output from the battery system to offer frequency regulation and peak shaving services.

The paper proposes a simulation model of a vanadium redox flow battery based on measurements with kilo watt scale. optimal number of modules for certain power levels during charging and discharging operations are estimated. The dependence of the overall system efficiency in a vanadium redox flow battery unit on the state of charge was determined by energy losses at stacks.

The paper is subsequently gone for showing a VRFB electrochemical element display, a wind cultivate made by five wind turbines and two diverse control systems for the capacity. The advantages and the issues of every control technique are highlighted with the assistance of the reenactments. The undertaking of the control techniques, called Power Control and Energy Control, is to give the coveted yield force of the framework capacity in addition to turbines, with unique respect to the power profile also, the vitality profile individually.

In this paper, a model utilizing just SOC as a state variable is picked with a specific end goal to precisely repeat the maker's bends for the four noteworthy sorts of battery sciences. These four sorts are: Lead-Acid, Lithium-Ion (Li-Ion), Nickel-Cadmium (NiCd) and Nickel-Metal-Hydride (NiMH). The paper is partitioned into three areas. In the main segment, the proposed model and its parameters are portrayed

The paper presents a different power converter interfaces that can be utilized for electrochemical vitality stockpiling frameworks are introduced. These interfaces have been partitioned into standard, multilevel and multiport innovation. The primary qualities and specificity of every topology considering its application to electrochemical vitality stockpiling frameworks are introduced.

This study demonstrates that the most extreme edge for the . Moreover, a strategy is introduced to demonstrate to decide the model parameters from the maker's release bends of the battery. In the second area, release bends are gotten by recreation what's more, approved with the producer's datasheets. capacity need is essentially not exactly the every day normal request. In the present study, we found that the surmised organize vitality stockpiling is of the request of 186 GW h/22 GW (roughly 22% of the normal day by day requests of California). Permitting vitality dumping was appeared to expand stockpiling use, and by that way, builds framework infiltration and lessens the required reinforcement routine limit prerequisites

#### **Proposed Methodology:- vanadium redox flow battery:-**

The VRFB abuses the capacity of Vanadium to exist in arrangement in four diverse oxidation states, and uses this property to make a battery that has only one electroactive component rather than two. In standard this implies regardless of the possibility that the layer is not great what's more, the arrangements move from one side to the next, the components will keep up their properties, i.e. there is no cross-defilement of various components permitting a similar component to be utilized boundless. Despite the fact that Vanadium is a copious component on earth, presently for the most part utilized as a steel added substance or ferrovanadium, its fundamental downside is its moderately low vitality thickness (roughly 25 Wh/L).

The VRFB framework additionally obliges association with capacity tanks and pumps, so that substantial volumes of the electrolytes can be circled through the cell, as can be found in Fig. 3. For these fundamental reasons, the frameworks are right now thought to be restricted to stationary applications, despite the fact that uncommon transportation applications have been tested.

The battery stores vitality by utilizing vanadium redox couples ( $V^{2+}/V^{3+}$  in the negative and  $V^{4+}/V^{5+}$  in the positive halfcells). These dynamic substance species are completely broken up at all times in sulphuric corrosive electrolyte arrangements. Amid the release cycle,  $V^{2+}$  is oxidized to  $V^{3+}$  in the negative half-cell and an electron is discharged to do work in the outside circuit (either DC or, for AC frameworks, through an AC/DC converter).

In the positive half-cell,  $V^{5+}$  as  $VO_2^+$  acknowledges an electron from the outside circuit and is lessened to  $V^{4+}$  as  $VO_2^+$ . Hydrogen ( $H^+$ ) particles are traded between the two half-cells to keep up charge lack of bias. The hydrogen particles diffuse through the anion or cation-particle penetrable polymer film that isolates the half cells. Charged

vanadium species and water can likewise diffuse over the layer. The cross-dispersion brings about direct vitality misfortune for that cycle.

However, The point when vanadium will be the just component available around both. Sides of the cell, this cross dissemination instrument doesn't bring about. Changeless ability loss, Similarly as long as the downright vanadium in the framework. Stays steady (i. E. , there may be no misfortune because of precipitation). For. A V\_\_\_\_\_ just framework there is no compelling reason should look after harmony the middle of. Sure Furthermore negative sides of the framework. In the certain halfcell,. Those vanadium may be available in result Similarly as oxy-cations. These. Oxy-cations need aid powerless on irreversible precipitation Likewise V2O5 On. Those electrolyte temperature surpasses 50–60 \_\_\_\_\_C. Moreover, when. Precipitation occurs, it commonly can Along these lines in the type about benevolent compounds,. Not V2O5.

Those ordinary operating temperature of a VRFB will be roughly. Between 10 What's more 40 \_\_\_\_\_C. On account for encompassing temperatures surpassing. 40–45 \_\_\_\_\_C animated cooling sub-systems are typically introduced.

The limit should cool the framework actively will be an advantage, since. Those framework might stay operating without risking any harm toit. Toward contrast, though coordinated circuit Mobile architectures overheat, the best. Alternative will be on stop utilizing them until they chill off. The cell voltage. Will be commonly 1. 4–1. 6 v Furthermore cell force densities bring a request from claiming. Extent about 100 mW/cm2.

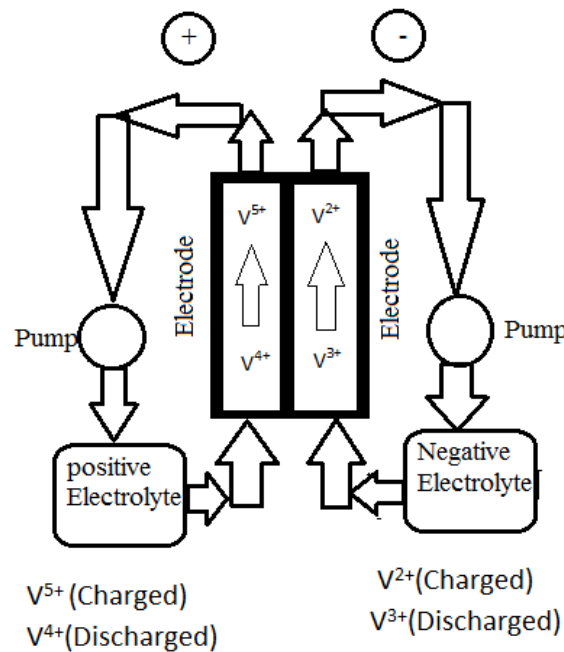
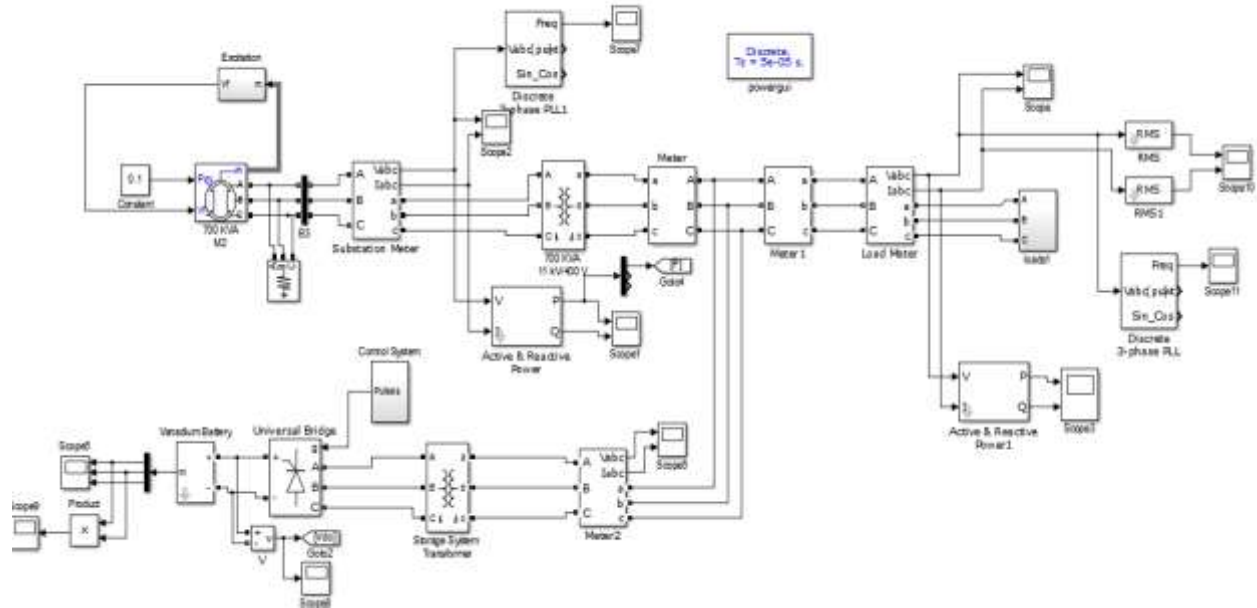

Fig 1:- Generic diagram of vanadium redox flow battery

As far as lifetime of the frameworks, vanadium-based stream vitality stockpiling frameworks can work for a considerable length of time. The dynamic fixing is a minimal effort, rechargeable electrolyte, which never wears out because of the kind of substance response included. The hardware what's more, programming to deal with the framework can be effortlessly updated like any PC. The plastic tanks utilized for holding the electrolytes are relied upon to last no less than 20 years. They are not influenced by quick charging and releasing varieties and profundity of release does not influence the lifetime of the framework. Vanadium-based frameworks are made for modern size applications from a couple of kilowatts to a few megawatts and there is no threat of warm responses. The creation procedure is likewise straightforward, and biologically sheltered. The electrolyte and other dynamic parts are consolidated as one process step. The walled in area made of channels, tanks and gadgets is gathered as a moment procedure step, and they are then amassed into battery packs.

**Methodology:-**

The to start with step in this examine might have been with Fabricate An model done MATLAB/. Simulink the place the recurrence variety Might be recognized Also. Those issue recognized. For this motivation behind a model of a micro dissemination. Grid might have been developed, which could



**Fig 2:-** Distribution grid model with Vanadium redox flow battery storage system.

Make seen done. The control. Framework toward the 11 kv terminals of the venture-down transformer will be. Modelled Likewise An synchronous generator for isochronous representative.

The synchronous generator likewise manages the voltage In its terminals. Toward 1 pu. The micro dissemination grid need an assembly of loads In. 400 V, speaking to business activity, An private neighborhood. What's more three charging station. Those model is based Previously, such An. Path that other loads alternately profiles might be acquainted to outperform files. Or specifically to MATLAB with the goal that they camwood be analysed. Furthermore,also separate capacity innovations could be used to look at those contrasts. Done giving work to the same administration What's more test exhibitions.

The EV burdens were considered to have 24 kW h battery limits what's more, equipped for being charged by load profile. The profiles were balanced in like manner to the time span utilized. The charging times were predicted to happen amid pinnacle times.Fast charging is thought to be performed from low (beneath 10%) SOC (State of Charge) until 100% SOC. Expecting a continuous stride, the charging has a regular term of 35 min at a greatest power of 50 kW and most extreme current of 67.5 A. The other quick charging profiles utilized take after comparable conduct, under the suspicion that a similar kind of vehicle is utilized.

A representation of a day by day stack profile was considered, however in a decreased time period for reproduction preparing .

The aggregate stack, which can be found , is measured at the substation level and in addition the recurrence variety exhibited indicates run of the mill valley hours which happen amid the night, took after by a first increment popular and a balancing out period ideal in the center of the profile .The higher request stage can be considered as the pinnacle hours of a day, which ordinarily happen toward the evening took after by a abatement of interest when the end of the day approaches. The recurrence movement amid the information profile is controlled by the generator senator to balance out its esteem to 50 Hz. The case superbly demonstrates the abundance of the recurrence variety when changes in load happen amid time, making the issue simple to distinguish. At whatever point a sudden

increment in the heap request happens, the recurrence diminishes. Then again if the request drops the recurrence will increment. The heap profile utilized created the framework's recurrence to have a greatest variety of 1.6%. From this to start with approach it can be watched that the conventional strategy for recurrence pay is working.

The framework is exceptional will perform two works (frequency. Regulation Also load shaving), it must a chance to be expected, that. Those two might make asked at those same occasion when. Otherwise, whether those stockpiling. Framework might have been needed with charge In An sure energy to adjust. To recurrence increment but, instantly after, gained An. Opposing request with supply force Throughout crest hours, those framework. Might main perform particular case capacity. To such reason, the two works. Ought further bolstering not be controlled independently, However Rather gatherings give. An net energy yield resultant from the recurrence and control supply response.

The Voltage source inverter (VSI) of the capacity framework is controlled. As stated by An traditional decoupled d-q hub control scheme,. The place the q-axis current manages those voltage toward the purpose from claiming association. Of the stockpiling framework (400 v terminal of the venture-down. Transformer), and the d-axis present manages those energy transferbetween those battery and the grid. Of specific enthusiasm may be the control rationale for the latter, which will be demonstrated over. Those controller. Of the d-axis current performs two capacities all the while. These. are recurrence regulation Furthermore net load regulation. Recurrence regulation. Is actualized as stated by established hang control (where.  $D_f = f_0 \frac{f - f_0}{f_0}$  f, continuously  $f_0$  the ostensible recurrence of the control system).

Those scope of the net load regulation will be to hold numerous those net load about. Those micro conveyance grid between 100 kw Furthermore 400 kw. Take. Note that those net load comprises both the generally load and the true. Energy injection/absorption of the capacity gadget (20 kW).

The battery will be set with an introductory SOC about half. It will charge or release. Throughout valley Furthermore top hours to recover its starting state. Those. Framework decided will be An business accessible result and it comprises of. A battery with ostensible accuse What's more release force of 20 kW, 48. VDC will 400 vac (3-phase). The inner imperviousness acknowledged. Might have been 0. 00861 X and the release bend profile could a chance to be. Seen for fig. 8. The framework acknowledges An 2C (1432 An) rate for the release. Current and An battery reaction time for 2 ms. The framework. Utilized recognizes displaying worth of effort In light of genuine living supplies.

### Result:-

After simulated the system in Fig.2 with and without storage system and results for frequency regulation and power supply services. The vanadium redox flow battery successfully provided both services. Result for frequency regulation can be observed in fig.3.It is observable that storage system provides regulated supply. Fig.4 shows the power behavior during simulation

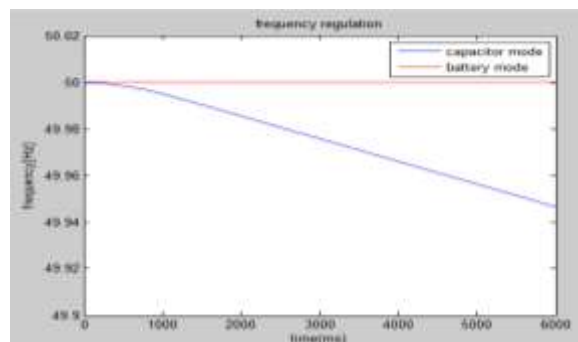

Fig.3:- Frequency variation with and without storage system

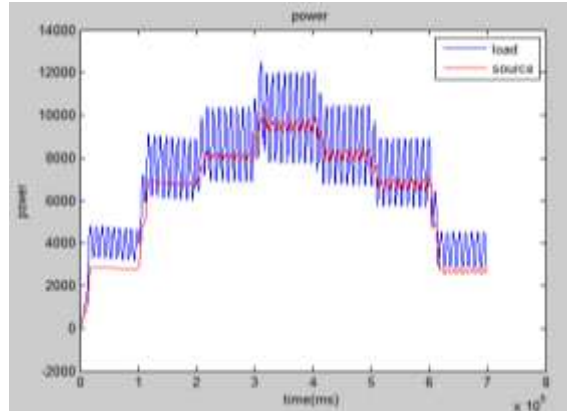

Fig.4:- power regulation with storage system

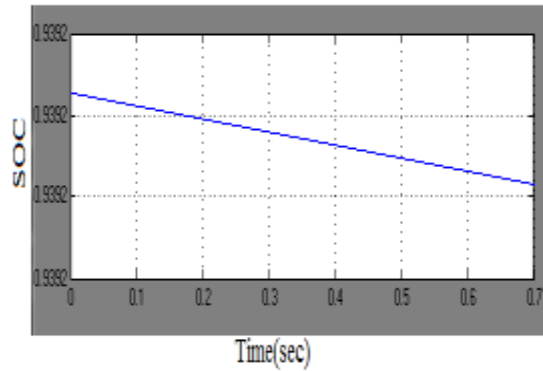

Fig.5:- charging period of storage system

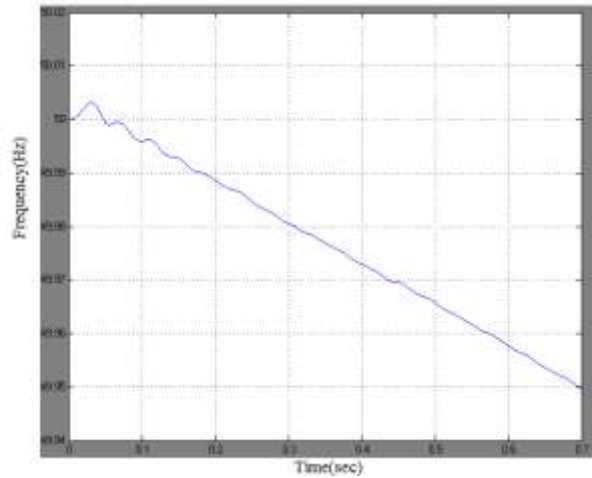

Fig.6:- without energy storage system frequency

**Conclusion And Futurework:-**

This paper presents the regulation of frequency and power supply services and comparison between with and without energy storage system. DESS is a powerful answer for request moving and top decrease where vitality request can be moved so as to match it with supply and to help with the joining of variable supply assets. In addition VRFB particularity attributes and high limit potential may empower even occasional stockpiling. With low self-release, it can store vitality for a considerable length of time, weeks, or months to make up for a more drawn out term supply disturbance or occasional changeability on the free market activity sides of the vitality framework. Futre work is to be adevelopment of a storage system model with distribution grid.fuzzy logic controller is type of controller will implementing of the area of reseach

**References:-**

1. Alexandre Lucas,Stamatios Chondrogiannis 2016.Smart grid energy storage controller for frequency regulation and peak shaving,using a vanadium redox flow battery .Electrical Power and Energy System 80(2016) 26-36.
2. The European Economic and Social Committee European Commission. 2015. Energy union package – a framework strategy for a resilient energy union with a forward looking climate change policy, Communication from the Commission to the Eurpean Parliament, the Council, the Committee of the regions and the European Investment Bank. Brussels; p. 40.
3. Technology roadmap: energy storage. 2014.International Energy Agency. Paris: OECD/IEA;. p. 110.
4. Ayodele TR, Ogunjuyigbe ASO. 2015;Mitigation of wind power intermittency:storagetechnology approach. Renew Sustain Energy Rev 44:447–56.
5. Energystorage.org.Frequency regulation, energy storage association.2015.Available at: <<http://energystorage.org/energy-storage/technology-applications-frequency-regulation>>; [accessed Feb. 2015].
6. Durand M Jean, Duarte M João, Clerens Patrick. 2013.European energy storage technology development roadmap towards 2030. Brussels: EASE/EERA;. p. 72.
7. Sbordone D, Bertini I, Di Pietra B, Falvo MC, Genovese A, Martirano L. 2015. : a real implementation in the smart micro grid paradigm .EV fast charging stations and energy storage technologies. Electr Power System;120:96–108.
8. Anuta OH, Taylor P, Jones D, McEntee T, Wade N. 2014. . Renew Sustain Energy Rev. An international review of the implications of regulatory and electricity market structures on the emergence of grid scale electricity storage;38:489–5
9. Vasconelos Jorge,Ruester Sophia,He Xian,Chong Eshien,Glachant Jean-Michel.2012;Electricity storage:how to facilitate its deploymentand operation in the EU(Topic 8).THINK,,European University Institute ;<http://dx.doi.org/10.2870/41846>.p.94.
10. Skyllas-kazacos M,Chakrabarti MH,Hajimolana SA,Mjalli FS .2011.saleem M.progress in flow battery research and development.J Electrochem Soc:158(8):R55
11. Burak Turker,Sebastian Arroyo Klein,Eva-Maria Hammer,Bettina Lenz,Lidiya Komsiyaska.2013.modelling a vanadium redox flow battery system for large scale applications.Energy Conversion management.p.26-32.
12. Baccino,F.;Grillo,s.;Marinelli,Mattia;Massucco,s.;Silvestro,F.2011.power and energy control strategies for a vanadium redox flow battery and wind farm combined system.In 2 nd IEEE PES International conference and Exhibition and Innovaties Smart grid Technologies:ISGT Europe.DOI:10.1109/ISGT.
13. Olivier Trembay,member IEEE,Louis-A.Dessaint,Senior IEEE,and Abdel-Allah Dekkiche.2007.A Generic Battery Model for the Dynamic Simulation of electric Vehicles;0-7803-9761-4/07.
14. V.Fernao Pries, Enrique Romero-Cadaval, D.Vinnikov, I.Roasto, J.F.Martins.2014.Power Converter interfaces for electrochemical energy storage systems-A review.Energy Conversion and Management 86.p.453-475.
15. A.A Solomon,Daniel M.Kammen,D.Callaway.2014.The role of large-scale energy storage design and dispatch in the power grid:A study of very high grid penetration of variable renewable resources.Applied Energy 134.p.75-89.