

| | | |
|---|---|---|
|  | <p>Journal Homepage: - www.journalijar.com</p> <h2>INTERNATIONAL JOURNAL OF ADVANCED RESEARCH (IJAR)</h2> <p>Article DOI: 10.21474/IJAR01/10563 DOI URL: http://dx.doi.org/10.21474/IJAR01/10563</p> |  |
|---|---|---|

REVIEW ARTICLE

A FLEX SENSOR BASED GESTURE CONTROLLED WHEELCHAIR

Dr. Narendra Kumar S., Dr. Lingayya Hiremath, Dr. Ajeeth Kumar S.³ and Dr. Praveen Kumar Gupta⁴

Assistant Professor, Department of Biotechnology, R.V.C.E, Bangalore.

Manuscript Info

Manuscript History

Received: 20 December 2019

Final Accepted: 22 January 2020

Published: February 2020

Abstract

Wheelchair is used by people who cannot move from one place to another on their own. This may be due to their illness or disability. As per Census 2011, there are over 27 million (2.7 Crore) people with disabilities out of which 5.4 million or 54 lakhs (54,36,826) have disability in movement in India. A small fraction of these have access to Wheelchairs i.e. around 80,000 to 1,60,000 people use wheelchair in India. This paves way for this project as a lot of disabled people require access to a wheelchair with a control of their own. This project is to provide the user a full control for the wheelchair with the help of flex sensors. These sensors take input from the user in the form of finger gestures and they drive the motor, which helps the wheels to move in the required direction. The required components such as Atmega32 microcontroller, L293D motor driver and LCD display and LEDs display the current status of the wheelchair.

Copy Right, IJAR, 2020., All rights reserved.

Introduction:-

More than a million individuals around the world, with physical handicaps require the help of a wheelchair yet only a few of them really possess or have the freedom of getting one. Though manual wheelchairs have demonstrated to be gainful for the impaired yet it has just filled the need of individuals with minor incapacities. Consider for a minute, an individual experiencing disabled legs. It turns out to be incredibly hard for such an individual to move, even inside the house. Such a person would require the help of others, even to complete his day by day tasks. Another option would be an electric wheelchair controlled by a joystick. Typical experience shows that a joystick requires a respectably colossal force which is more than the edge for truly debilitated people. Taking into thought, the force and the amazing cost of wheelchairs open in the market, this paper delineates the structure of a less complex to-control wheelchair. The paper exhibits a control-strategy to move a motorized wheelchair essentially by the improvement of fingers. It targets uniting the present day strategies for wheel seat components and control and simultaneously making it insightful, with the objective that it is sensible to the ordinary masses. The objective of this project is to build up a wheelchair framework which controls its development by the simple movement of an individual's fingers. Extraordinary sort of sensors known as 'flex-sensors' are inserted into a hand glove so as to accomplish the ideal objective. This is to help the correspondence of harshly debilitated individuals and improve the moving of the vehicle with the utilization of hand developments. The proposed model will be imparting remotely between the controller and the plant and it will likewise supplant the conventional joystick by the usage of client hand glove control.

Components required and their Interaction

The components required in this project are:-

Corresponding Author: Dr. Narendra Kumar S
Address:- Department of BT, R.V.C.E, Bangalore.

Flex sensors:

The flex sensor is a type of variable resistor. The resistance of the flex sensor increases as the body of the component bends. It is due to this property it has a wide range of applications.

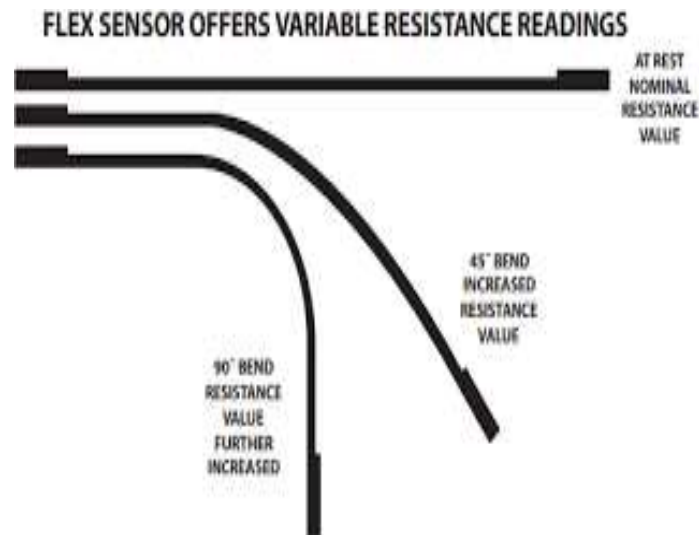

Fig 1:- Flex sensor.

Atmega32Microcontroller:

ATmega32 is a low power CMOS 8-bit microcontroller based on RISC architecture. It takes flex sensor input from the internal Analog to Digital controller. It rotates the motors in forward or reverse direction to move the wheelchair.

L293D motordriver:

L293D IC is a typical Motor Driver IC which allows the DC motor to drive on any direction. This IC consists of 16-pins which are used to control a set of two DC motors instantaneously in any direction.

LCD Display:

A 16x2 LCD display is used to display the current status of the wheelchair. When the wheelchair moves in the required direction, the LCD gets the input from the microcontroller and the message is displayed on the screen.

LEDs:

It indicates wheelchair's direction of movement i.e. forward, reverse, left or right.

DC Motors:

Four DC motors are used to move the wheelchair in all the four directions: forward, backward, left and right.

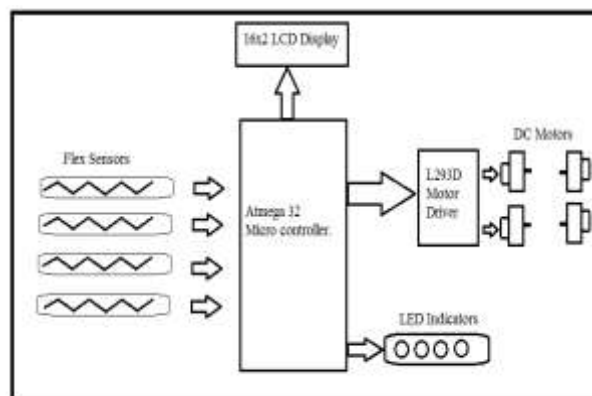

Fig. 2:- Block Diagram of Interaction between components.

Methodology:-

Figure 2 shows the block diagram of the complete system .It consists of Flex sensors, micro controller, LCD display, LEDs, motor driver and DC motors. In this project system consists of two components the system on the gloves and the system on the wheelchair. The system on the gloves consists of Flex Sensors and the other comprises of Microcontroller, LCD display, motor driver, DC motors.

The input is taken from the user in the form of finger gestures through the flex sensors.The flex sensors have a property that when they are bent their resistance changes and the current starts to flow.The input of the flex sensor is given to the Atmega 32 microcontroller through the internal ADC. The microcontroller does the necessary calculations (works as an analog to digital converter and converts the data into serial data) and sends the signals serially to the motor driver and the LCD display.

The microcontroller is programmed according to the variation in the input.The output of the microcontroller is then given to the motor driver which drives the motor in the required direction.Hence, the wheelchair begins to move according to the movement or bending of the user's fingers.

Results and Discussion:-

The purpose of this project is to provide a 'Gesture controlled Wheelchair' to the disabled people which is economical. The project involves the use of sensors and a 8 bit microcontroller and flex sensors. When the flex sensor is bent at an angle of 45° , the resistance changes. This causes the wheel chair to move. The project can be used to provide a low cost and technologically useful wheelchair with the help of electronics to the disabled people and is also capable of performing all the tasks which are performed by the advanced wheel chairs, at a much lower cost.

Conclusion:-

In this paper, a new method of wheel chair control is discussed and is implemented. The prototype for the system is developed which is believed to be better because of low cost and also of lesser amount of force is required to use as compared to the joystick-control system, in which more force is required to move it. Further improvement includes a new system for improving the obstacle avoidance and to include the braking system.

References:-

1. T.G.Zimmerman et al., "A Hand Gesture Interface Device." Proc. Human Factors in Computing Systems and Graphics Interface, ACM Press, New York, April 1987.
2. Ruzaij M F, Neubert S, Stoll N, et al. Multi-sensor robotic-wheelchair controller for handicap and quadriplegia patients using embedded technologies[C]. International Conference on Human System Interactions. IEEE, 2016:103-109.
3. Mohammed FaikRuzaij, S. Poonguzhali, "Design and Implementation of Low Cost Intelligent Wheelchair", in Proc. Second International Conference on Recent Trends in Information Technology, Chennai, India, April 19-21, 2012, pp. 468-471.
4. Faudzi A M, Ali M H K, Azman M A, et al. Real-time Hand Gestures System for Mobile Robots Control[J]. Procedia Engineering, 2012, 41:798-804.
5. Chen K Y, Chien C C, Chang W L, et al. An integrated color and hand gesture recognition approach for an autonomous mobile robot[C]// International Congress on Image and Signal Processing. IEEE, 2010:2496-2500.
6. R. Akmeliawati, F. S. Ba Tis and U. J. Wani, "Design and development of a hand-glove controlled wheel chair", in 4th International Conference on Mechatronics (ICOM), 2011.
7. R. A. Kalantri and D. Chitre, "Automatic Wheelchair using Gesture Recognition", International Journal of Engineering and Innovative Technology (IJEIT), vol. 2, no. 9, pp. 216-218, 2013.
8. P. Pande, N. Ubale, D. Masurkar, N. Ingole and P. Mane, "Hand Gesture Based Wheelchair Movement Control for Disabled Person Using MEMS", International Journal of Engineering Research and Applications (IJERA), vol. 4, no. 4, pp. 152-158, 2014..
9. G. Soni, V. Poddar, Y. Sahu and P. Suryawanshi, "Hand Gesture Recognition Based Wheel Chair Direction Control Using AVR Microcontroller", International Journal of Advanced Research in Computer and Communication Engineering, vol. 5, no. 3, pp. 344- 348, 2016.