



ISSN NO. 2320-5407

Journal homepage: <http://www.journalijar.com>

INTERNATIONAL JOURNAL  
OF ADVANCED RESEARCH

## RESEARCH ARTICLE

# POWER OPTIMIZATION IN WIRELESS SENSOR NETWORKS USING ZIGBEE

Dr. Krishna Mohanta and Dr V Khanaa

Sri Ramanujar Engineering College Chennai 600 073 and Bharath University Chennai 600 073

### Manuscript Info

#### Manuscript History:

Received: 25 July 2014

Final Accepted: 26 August 2014

Published Online: September 2014

#### Key words:

Wireless sensor networks, decentralized parameter estimation, opportunistic communications, RSSI ranging, multilateral positioning, adjacent correction algorithm

#### \*Corresponding Author

Dr. Krishna Mohanta

### Abstract

A wireless sensor network (WSN) consists of spatially distributed autonomous sensors to monitor physical or environmental conditions, such as temperature, sound, pressure, etc. and to cooperatively pass their data through the network to a main location. The main concept of this project is to reduce power while transmitting through zigbee. Here temperature and humidity sensors are used. After sensing it transmits the data to fusion center through zigbee. By finding the accurate distance of the node power is allocated. For that two algorithms are used Opportunistic Power Allocation (OPA) and Adjacent Correction Positioning (ACP). OPA algorithm can achieve three following process Minimization of distortion, Minimization of transmit power, enhance the network lifetime. It can be able to find the distance of the nodes and allocate the power but it is not accurate. RSSI in OPA cannot find the accurate position of the nodes so that it consumes more power. ACP algorithm finds the accurate position of the nodes and reduces the power when the data's are transmitted through zigbee.

Copy Right, IJAR, 2014., All rights reserved.

### Introduction

TYPICALLY, a Wireless Sensor Network (WSN) consists of one Fusion Center (FC) and a potentially large number of energy-constrained sensor nodes deployed in order to sense or detect a given phenomenon (temperature, pressure, etc). This fact has spurred lots of interest in distributed signal processing techniques that, while exhibiting energy-efficient and low-complexity features, allow for the optimization of the estimation accuracy, probability of detection, etc. The development of wireless sensor networks was motivated by military applications such as battlefield surveillance. They are now used in many industrial and civilian application areas, including industrial process monitoring and control, machine health monitoring, environment and habitat monitoring, healthcare applications, home automation, and traffic control.

In addition to one or more sensors, each node in a sensor network is typically equipped with a radio transceiver or other wireless communications device, a small microcontroller, and an energy source, usually a battery. The main drawbacks of [2] are (i) the need for global (i.e. all the terminal-to-BS channel gains) and perfect CSI at the FC; and (ii) the computational complexity that water-filling solutions entail. Size and cost constraints on sensor nodes result in corresponding constraints on resources such as energy, memory, computational speed and bandwidth. In recent works [4], the authors show how a sensible use at the scheduler of Residual Energy Information(REI) and CSI information is key to extend the time for which the network remains operational.

In this paper, we propose and analyze a class of Opportunistic Power Allocation (OPA) with Adjacent Correction Positioning Algorithm. Opportunistic Power Allocation algorithm can able to achieve the following process they are as follows: Minimization of distortion (OPA-D), Minimization of transmits power (OPA-P),

Enhancement of network lifetime (OPA-LT). It can be able to find the distance of the node based upon the RSSI measurement. RSSI is the Received Signal strength indication used to measure the signal strength in a wireless environment. Higher the RSSI value stronger the signal. RSSI in Opportunistic power allocation cannot find the accurate position of the nodes so that it consumes more power. Adjacent correction positioning (ACP) algorithm finds the accurate position of the nodes and reduces the power when the data's are transmitted through zigbee. The weighted average recursive filtering algorithm and smooth factor do a simple process for the RSSI signal. It is used to reduce the influence caused by unilateral ranging error in the calculation of multilateral positioning. The N active sensor nodes adjust their transmit power accordingly and send their observations to the FC (Fusion Center).

## 2. Block diagram

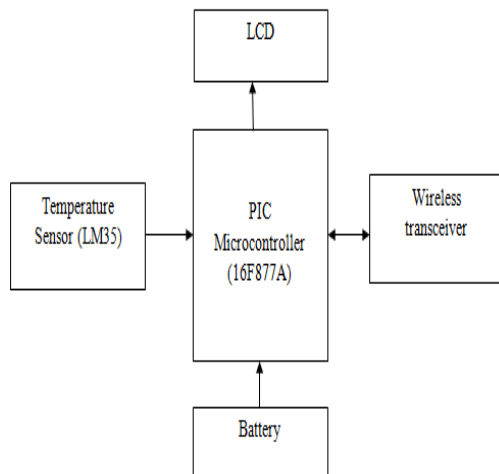

**Figure 2:** Transmitter unit – Node 1

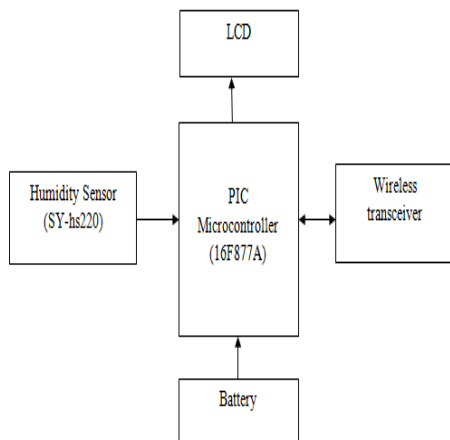

**Figure 3:** Transmitter unit – Node 2

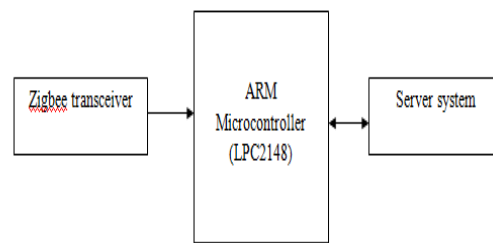

**Figure 4: Fusion Center**

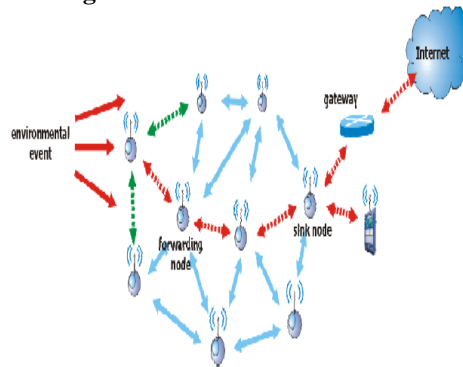

**Figure 1: Wireless Sensor Network**

The main concept of this project is to reduce power while transmitting through zigbee. Here temperature and humidity sensors are used. After sensing it transmits the data to fusion center through zigbee. And the sensed value displayed in the Liquid crystal display. In the transmitting unit there are two nodes. And the receiving unit is considered as the fusion center. By finding the accurate distance of the node power is allocated.

### 3. Algorithm

#### ADJACENT CORRECTION POSITIONING ALGORITHM

In the existing system Opportunistic power allocation algorithm is used. OPA cannot find out the accurate distance. For better accuracy going for ACP algorithm. Some of the steps are as follows:

- 1) **Initialization:** Compute and broadcast the reporting threshold  $\gamma^{\text{th}}$ .
- 2) **Identification of the active sensor set:** Each sensor node notifies the FC whether it will participate in the estimation process or not. Only sensors above the threshold will participate. The number of active sensors  $N$ , is then broadcasted by the FC.
- 3) **Aggregate Routing:** Set/read time between consecutive aggregate route broadcast messages. If used, AR should be set on only one device to enable many-to-one routing to the device. Setting AR to 0 only sends one broadcast
- 4) **Power Allocation and Transmission:** The  $N$  active sensor nodes adjust their transmit power accordingly and send their observations to the FC.
- 5) **Go to Step 2.**

In order to improve the location accuracy further, an adjacent correct location algorithm has been applied in this system; the main purpose of the algorithm is to reduce the influence of unilateral ranging error in the process of multilateral positioning calculation. Its principle can be described in figure.

Suppose the system is composed by one blind node, one adjacent node, and eight reference nodes. The coordinate of blind node is  $B(x, y)$ , the coordinate of correction node is  $C(\Delta x, \Delta y)$ , and the eight reference nodes' coordinate is  $R_1(x, y)$ ,  $R_2(x, y)$ ...  $R_8(x, y)$ . Suppose the correction node had been arranged on a circle which the center point is  $B(x, y)$  and radius is  $r$ . In order to describe the algorithm distinctly, define several different concept of distance as follow:

- Step 1:** Mark the actual distance between reference node  $R_n$  and correction node  $C$  as  $d_{\Delta n}$ .
- Step 2:** Mark the measured distance between reference node  $R_n$  and correction node  $C$  as  $d'_{\Delta n}$ .
- Step 3:** Mark the measured distance between reference node  $R_n$  and blind node  $B$  as  $d_n$ .
- Step 4:** Mark the measured distance between reference node  $R_n$  and correction node  $C$  as  $d'_{\Delta n}$ .

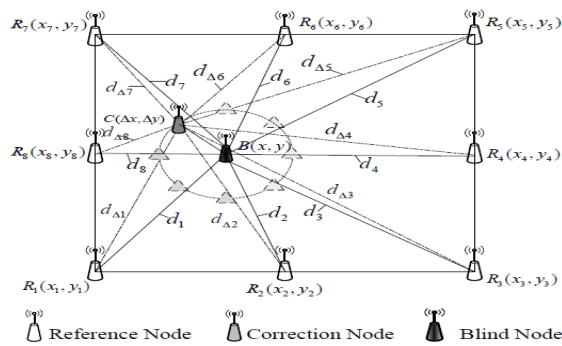

**Figure 5:** Adjacent Correction Positioning

In the positioning calculation process, the correction factor  $\eta$  and difference coefficient will be applied, make its definition as below:

Definition 1: The correction factor  $\eta$  is the sum of every relative measure error between reference node and correction node.

Definition 2 : The discrimination coefficient between reference node  $R_n$  and blind node B is  $\mu_n$ . The range error between reference nodes  $R_n$  and correction node C is  $n \varepsilon$  :

$$\varepsilon_n = d_{\Delta n} - d_{\Delta n}$$

Afterwards, the correction processing distance between reference  $R_n$  and blind node B is  $d_n : d_n = d_n - \mu_n \varepsilon_n$

### 3.1 Flow chart

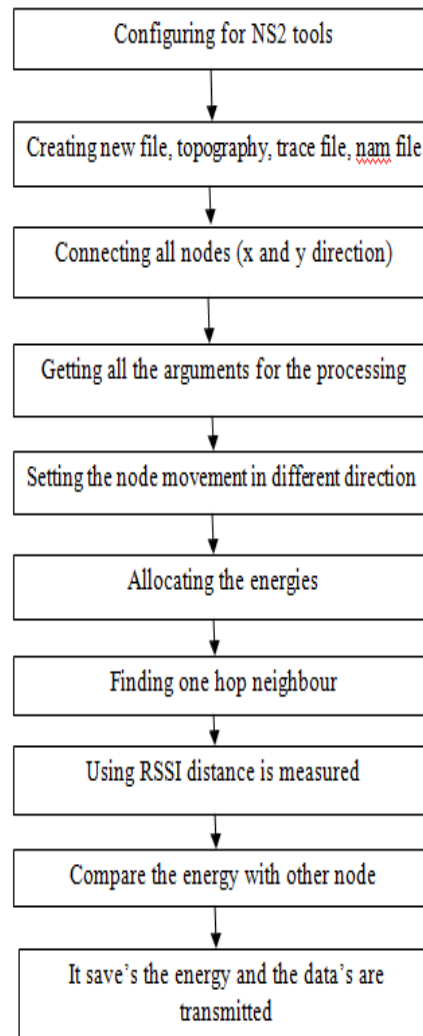

**The Network Simulator is a most widely used network simulator. AODV configures using TCL script. AODV routing protocol is based on Destination sequenced distance vector routing and dynamic source routing algorithms. It minimizes the number of broadcasts by creating routes on-demand that maintains the list of all the routes. To find a path to the destination, the source broadcasts a route request packet. The neighbours broadcast the packet to their neighbours till it reaches an intermediate node that has the recent route information about the destination.**

### 3.2 Methodology

A source initiates the process by demanding a neighbour discovery process. It get backs the RSSI from each and every node. Next it selects the node with higher RSSI and transmits the packet through that node, whereas remaining nodes are in the sleep state. In the next means of packet transmission, the energy of every node is taken into account, and the node with lower remaining energy is used as the forwarding node to transmit packet to the destination. An effective usage of energy of every node in the network is utilized and energy consumption is attained to a greater extent. Efficient network node energy is obtained.

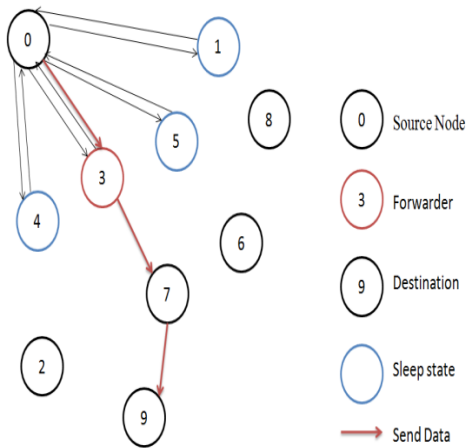

Figure 6: Methodology

3.3 Simulated results

Node	One hop neighbour
node (0) node (0) node (0) node (0)	node (1) node (3) node (4) node (5)
node (1) node (1) node (1)	node (0) node (3) node (5)
node (3) node (3) node (3) node (3)	node (0) node (1) node (4) node (5)
node (4) node (4)	node (0) node (3)
node (5) node (5) node (5)	node (0) node (1) node (3)
node (6)	node (7)
node (7) node (7)	node (6) node (9)
node (9)	node (7)

Figure 7: One hop neighbouring

This figure shows the One hop neighbouring for all the nodes. Here for Node 0 four nodes are the nearest nodes. The nodes are Node 1,3,4,5.

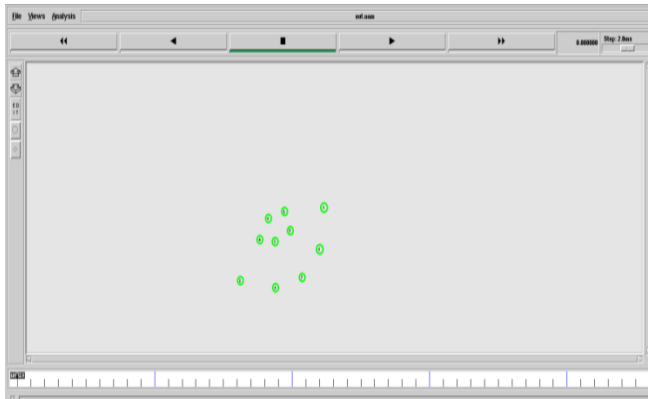

**Figure 8:** Initial stage of the Nodes

This is the initial stage of the nodes. There are totally 10 nodes. Node 0 is the source node. It initiates the process by demanding a neighbour discovery process.

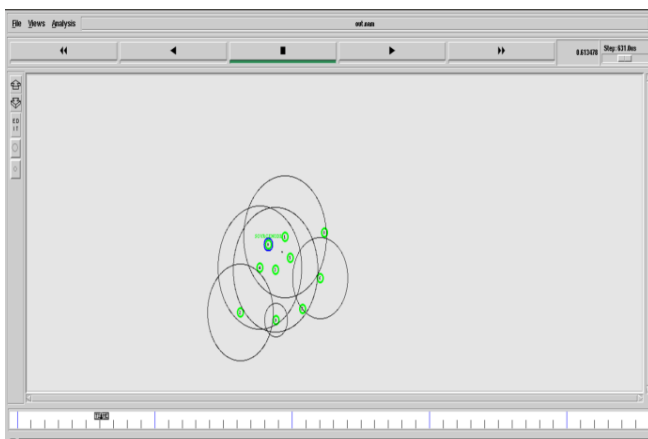

**Figure 9:** Routing

It starts finding the one hop neighbour process and get backs the RSSI from each and every node. Next it selects the node with higher RSSI and transmit the packet.

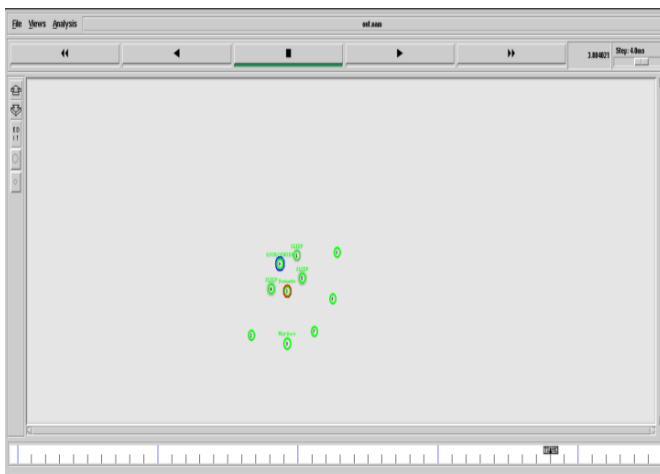

**Figure 10:** Packet transmission

Node 9 is the farthest node to the source node. Here the energy of every node is taken into account and node with highest RSSI is used as the forwarding node to the destination. Hence the node 3 becomes the forwarder.

**Table 1:** Power consumption for one hop

NODE 0	-e97.1999
NODE 1	-e95
NODE 3	-e94.95
NODE 4	-e97
NODE 5	-e96

This is the table for one hop neighbouring and the power consumption for the 5 nodes.



**Figure 11:** Graph

This is the graph plotted for distance vs power. If distance increases then the power requirement also increases.

#### 4. Conclusion

Thus the accurate distance of the node is measured based upon the Received signal strength indication by ACP algorithm. An adjacent node is brought into the position area, through the adjacent correction algorithm to reduce the influence caused by unilateral ranging error in the calculation of multilateral positioning, so as to amend the positioning result. Hence the transmit power has been minimized based upon the distance. Simulated output results obtained using simulation tool NS2.

#### References

- [1] Anto n-Haro and Javier Matamoros, "Opportunistic Power Allocation and Sensor Selection Schemes for Wireless Sensor Networks", IEEE transactions on Wireless communications, Vol. 9, no. 2, February 2013.
- [2] Amit Jain, Sunghyun Choi, "Adaptive Transmit Power Control in IEEE 802.11a Wireless LANs", IEEE transactions on Signal processing, Vol. 55, no. 9, September 2012.
- [3] S. Cui, J. Xiao, A. Goldsmith, Z.-Q. Luo, and H. V. Poor, "Estimation diversity and energy efficiency in distributed sensing," IEEE Trans. Signal Process., vol. 55, no. 9, pp. 4683–4695, Sep. 2007.
- [4] W. Yu and M. Cioffi, "Constant-power waterfilling: performance bound and low-complexity implementation," IEEE Trans. Commun., vol. 54, no. 1, pp. 23–28, Jan. 2006.
- [5] Y. Chen, Q. Zhao, V. Krishnamurthy, and D. Djonin, "Transmission scheduling for optimizing sensor network lifetime: a stochastic shortest path approach," IEEE Trans. Signal Process., no. 5, pp. 2294–2309, May 2007.



- [6] Jin-Jun Xiao, Shuguang Cui, Zhi-Quan Luo, "Estimation Diversity and Energy Efficiency in Distributed Sensing", IEEE transactions on Signal Processing, Vol. 55, no. 9, September 2007.
- [7] S. Boyd and L. Vandenberghe, Convex Optimization. Cambridge University Press, 1993.
- [8] R. Corless, G. Gonnet, D. Hare, and D. Jeffrey, "On the Lambert  $W$  function," Advances in Computational Mathematics, vol. 5, pp. 329–359, 1996.
- [9] A. B. Gershman and N. D. Sidiropoulos, Space-Time Processing for MIMO Communications. J. Wiley & Sons, Ltd, 2005.
- [10] JooHwan Kim, Xiaojun Lin, "Minimizing Delay and Maximizing Lifetime for Wireless Sensor Networks With Anycast", August 2005.